

# IQaudio

# User Guide

**This document covers the installation, software configuration and usage of IQaudio audio cards for the Raspberry Pi.**

If you would like to see additional information within this document please email us at [info@iqaudio.com](mailto:info@iqaudio.com)

**For those who simply need the /boot/config.txt details → Just jump to section 1**

# IQaudIO user instructions

## Contents







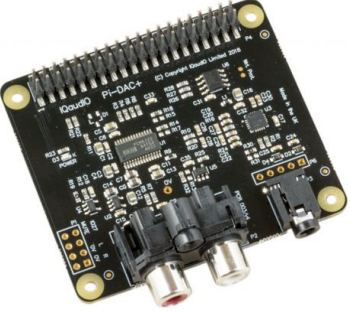

- 1) Getting started
- 2) The NEW Pi-DAC+
- 3) The NEW Pi-DigiAMP+
- 4) The NEW Pi-DAC PRO
- 5) The Pi-AMP+
- 6) The Pi-Digi+
- 7) The Pi-DACZero / ZeroHeadphone
  
- 8) Connecting the Pi-DAC+ to your Raspberry Pi
- 9) Connecting the Pi-DigiAMP+ to your Raspberry Pi
- 10) Connecting the Pi-AMP+ to your Pi-DAC+
  
- 11) Building the Raspberry Pi and IQaudIO sound cards into your Pi-CASE+
- 12) Configuring Linux/Raspbian to include sound card support
- 13) Checking audio is working through the IQaudIO sound card
- 14) Advanced troubleshooting
  
- 15) Controlling the Pi-AMP+ or Pi-DigiAMP+'s Mute / Un-mute
- 16) Common Linux audio distribution configurations
  
- 17) Advanced hardware information
- 18) Adding a Rotary Encoder (Physical volume control)
  
- 19) Sonic\_Pi and IQaudIO
- 20) Storing alsamixer settings
- 21) Using external USB devices
- 22) MPD based audio with volume control
- 23) Useful data (screw sizes / part numbers / wire gauge size etc.)

## 1) Getting Started

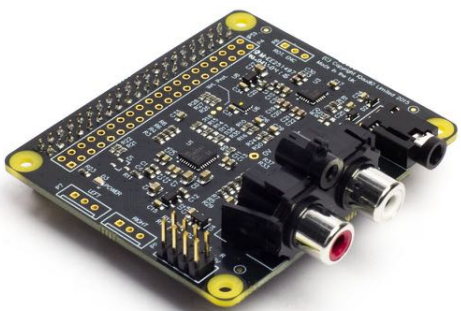
Thank you for choosing an IQaudIO sound card. Next you need to play music, but first you may need to configure the Raspberry Pi's and software package you want to use.

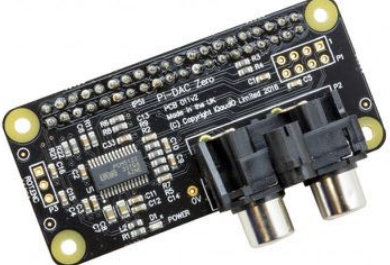
### The IQaudIO product family.

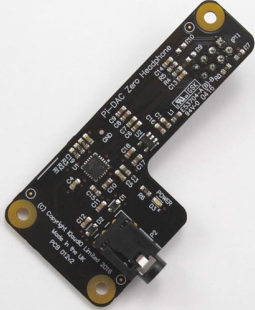
The IQaudIO sound cards are all designed to work with the current Raspberry Pi, those that have a 40way male GPIO pin header. This includes the Pi3, Pi3B+, Pi-Zero etc. Some of our products are full size (HAT) boards for the full size Raspberry Pi, and others are more suited to the Pi-Zero form factor. We also have accessory boards that either act as accessories to our sound cards or can be used standalone (such as the CosmicController).

Pi-DAC+	Pi-DigiAMP+	Pi-DAC PRO
		
Phono (RCA) and headphone output	Speaker output	Phono (RCA), Balanced and headphone output
Pi-Digi+	Pi-DACZero+	Pi-AMP+
		
Optical (Toslink) and SPDIF output	Phono (RCA) output	Speaker output (accessory to the Pi-DAC+ and Pi-DAC PRO)
DACZero Headphones	CosmicController	GPIO Expander
		
Headphone output (accessory for the Pi-DACZero)	3xLED, 3xButtons, Rotary Encoder & 128/64 OLED display	Double the access to the Pi's standard GPIO pins

You will find several audio applications with pre-configured Raspberry Pi SD Card images on [www.iqaudio.com/downloads](http://www.iqaudio.com/downloads) . We also include a quickest images which will help you check that you have the IQaudIO sound card installed correctly on your Raspberry Pi.

Each IQaudIO sound cards has a specific purpose / is designed for specific use cases. Select the board that best integrates with your existing HiFi equipment. If you don't have any existing equipment then simply buy a set of speakers and use the Pi-DigiAMP+.

<b>IQaudio Card</b>	<b>Headphones</b>	<b>Line Out (RCA)</b>	<b>Balanced (XLR)</b>	<b>Speakers</b>	<b>Digital Output</b>
Pi-DAC+	★	★			
Pi-DAC+ / AMP+	★	★		★	
Pi-DigiAMP+				★	
Pi-DACZero		★			
Pi-DACZero Headphones	★				
Pi-DAC PRO	★	★	★		
Pi-DAC PRO / AMP+	★	★	★	★	
Pi-Digi+					★

## Enabling the IQaudio sound card in Raspbian / example SD card images.

By default all our latest full size audio boards include a pre-programmed EEPROM. This allows the Raspberry Pi operating system to auto detect and auto configure itself allowing the IQaudio boards to be plug and play.

If however you are using an older version of our board, or a Pi-Zero type board then you may have to configure the Raspberry Pi operating system yourself. This is done by editing the Pi's configuration file (found at `/boot/config.txt`) and ensuring the correct device tree overlay is included. This is also how you disable the Pi's onboard audio if it exists.

We've included below the entries needed for the IQaudio boards and also the quickest image that can be downloaded from our website.

The following will help you check your sound card is working and it's configured correctly.

IQaudio Card	/boot/config.txt	Quicktest img
Pi-DAC+	<code>dtoverlay=iqaudio-dacplus</code>	IQ_0_quicktestDAC_DigiAMP_AMP.zip
Pi-DigiAMP+	<code>dtoverlay=iqaudio-dacplus,unmute_amp</code> or <code>dtoverlay=iqaudio-dacplus,auto_mute_amp</code>	IQ_0_quicktestDAC_DigiAMP_AMP.zip
Pi-DACZero	<code>dtoverlay=iqaudio-dacplus</code>	IQ_0_quicktestDAC_DigiAMP_AMP.zip
Pi-DAC PRO	<code>dtoverlay=iqaudio-dacplus</code>	IQ_0_quicktestDAC_DigiAMP_AMP.zip
Pi-Digi+	<code>dtoverlay=iqaudio-digi-wm8804-audio</code>	IQ_0_quicktestDigi.zip

## Disabling the standard Raspberry Pi On-Board Audio

You may want to disable the Raspberry Pi's on-board "low quality" audio card. This is done simply by commenting out the `dtparam=audio=on` device tree parameter in your `/boot/config.txt` file by placing a `#` at the start of the line, saving the file and rebooting

```
#dtparam=audio=on
```

## People refer to “Headless” software. What is it?

Many of the software packages used with the Raspberry Pi simply turn the Pi into a Headless end-point. That is to say that it doesn't need to or expect a screen to be attached to the Pi's HDMI socket.

So if there's no screen how do you control it?

Well in some cases you don't need to do anything with the Pi at all. Take the RoonLabs images, these turn the Pi into a Roon Certified end-point. The Pi is then controlled from the RoonLabs PC/ Mac application which connects to and plays music through the IQaudIO sound card. No screen needs to be attached to the Pi itself.

Other “headless” applications install a web server onto the Pi, so to control it you simply open a browser window on your PC / Mac / Tablet or similar and interact with the Pi based application through a web page. Applications such as [Max2Play](#), [MoodeAudio](#), [Volumio](#) and [RuneAudio](#) work this way.

Max2Play - visit their getting started page here: [Max2Play](#)

### Max2Play - IQAudio Edition

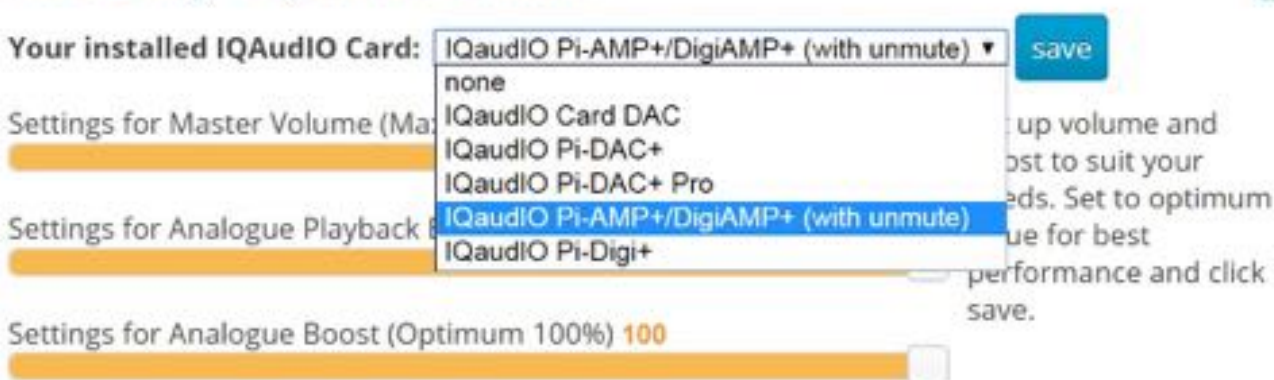

Volumio:

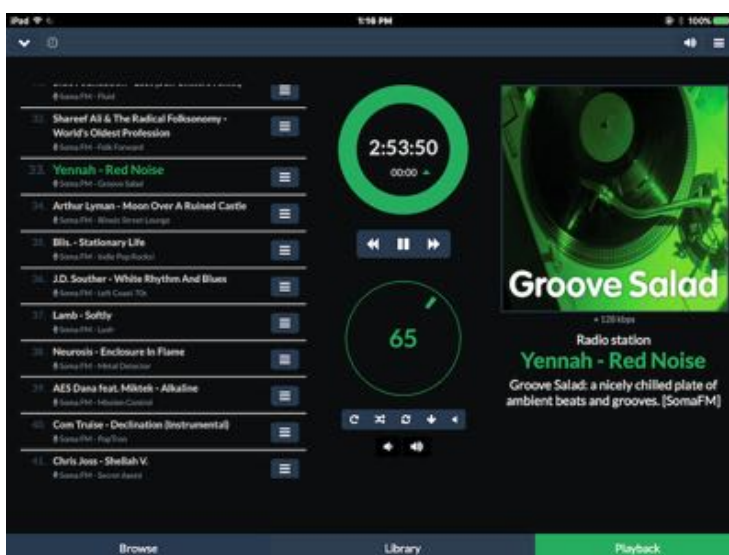

## How do I install software on the Pi?

The Raspberry Pi loads its software from the micro-SD card. Most audio applications assume they are the only thing running on the Pi so most require a dedicated SD card. The applications are normally distributed as a compressed .img file (likely a .zip or .gz file) and this .img file will need to be written to the Pi's SD card to allow the Pi to boot.

Can't I just copy the .img file over to the Pi?

Err, no. Doing this will just store the .img file on the SD card. The Pi needs the SD card to be formatted in a particular way to allow it to boot / start up and run. Don't worry, there are several ways to do this and some are VERY simple.

Got a Mac? Get ApplePi-Baker - <https://www.tweaking4all.com/>



Use Windows? Use Win32DiskImager - <https://sourceforge.net/projects/win32diskimager/>



Top Tip: Buy a few extra micro SD cards, you'll find it much easier to try things. Also, once you have a working Pi SD card, back it up to your PC/Mac. It's easier to re-write the SD card if things go wrong.

## 2) The NEW Pi-DAC+

The Pi-DAC+ is a fully HAT compliant add-on accessory for the Raspberry Pi A+/B+/Pi2/RPi3/RPi3B+.

The Pi-DAC+ takes the digital audio signals (I2S) from the Raspberry Pi and through the onboard Texas Instruments PCM5122 DAC delivers variable output (hardware volume control) analog audio to the Pi-DAC+'s Phono connectors. The Pi-DAC+ also, via the Texas Instruments TPA6133A headphone amp, supports the direct use of headphones via the Pi-DAC+'s 3.5mm audio jack.

The Pi-DAC+ can be connected to the Raspberry Pi's 40way pin header without any additional soldering.

Component selection and track layout have been in the forefront of our design to ensure noise immunity and best possible audio playback with the Pi-DAC+.

Raspberry Pi GPIO header

HAT EEPROM Write Enable

Headphone Socket

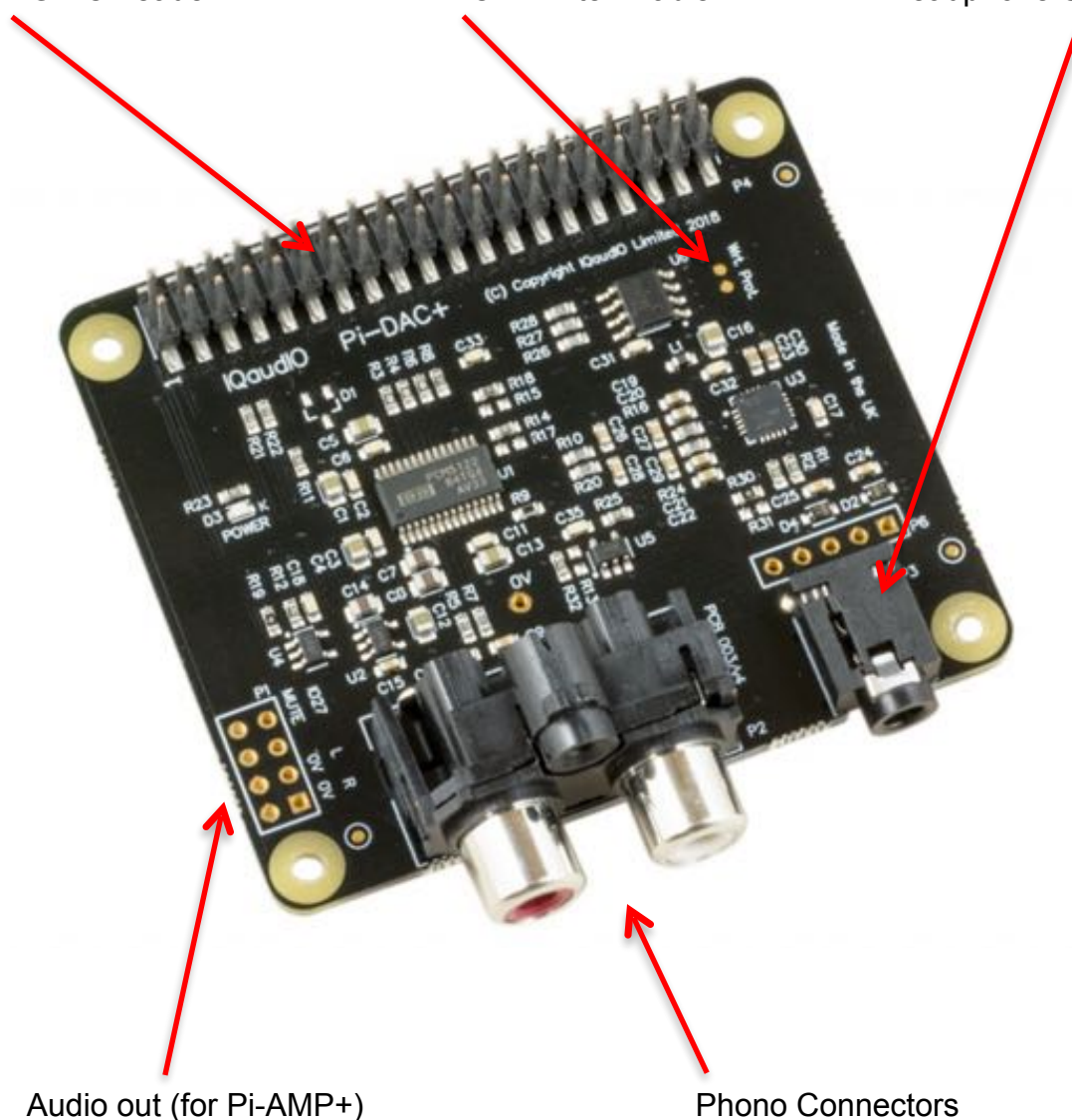

Audio out (for Pi-AMP+)

Phono Connectors



### 3) The New Pi-DigiAMP+

The Pi-DigiAMP+ is a fully HAT compliant add-on accessory for the Raspberry Pi.

The Pi-DigiAMP+ takes the digital audio signals (I2S) from the Raspberry Pi and through the onboard Texas Instruments TAS5756M PowerDAC delivers direct connection to stereo speakers at up to 2x35w with variable output.

The Pi-DigiAMP+ can be connected to the Raspberry Pi A+/B+/RPi2 or RPi3's 40way pin header without any additional soldering. The Pi-DigiAMP+ requires a 12-24 volt power source to operate. Power should be applied via the Pi-DigiAMP+'s standard barrel connector or can be applied via the (no fit) two pin header provided.

The Pi-DigiAMP+, when powered, has been designed to provide power to the Raspberry Pi and Pi-DigiAMP+ combination safely. You can continue to use your Pi devices without risk of damage. The amplifier is by default muted at power on (mute LED lit). Mute state / LED is under software control (Raspberry Pi GPIO22).

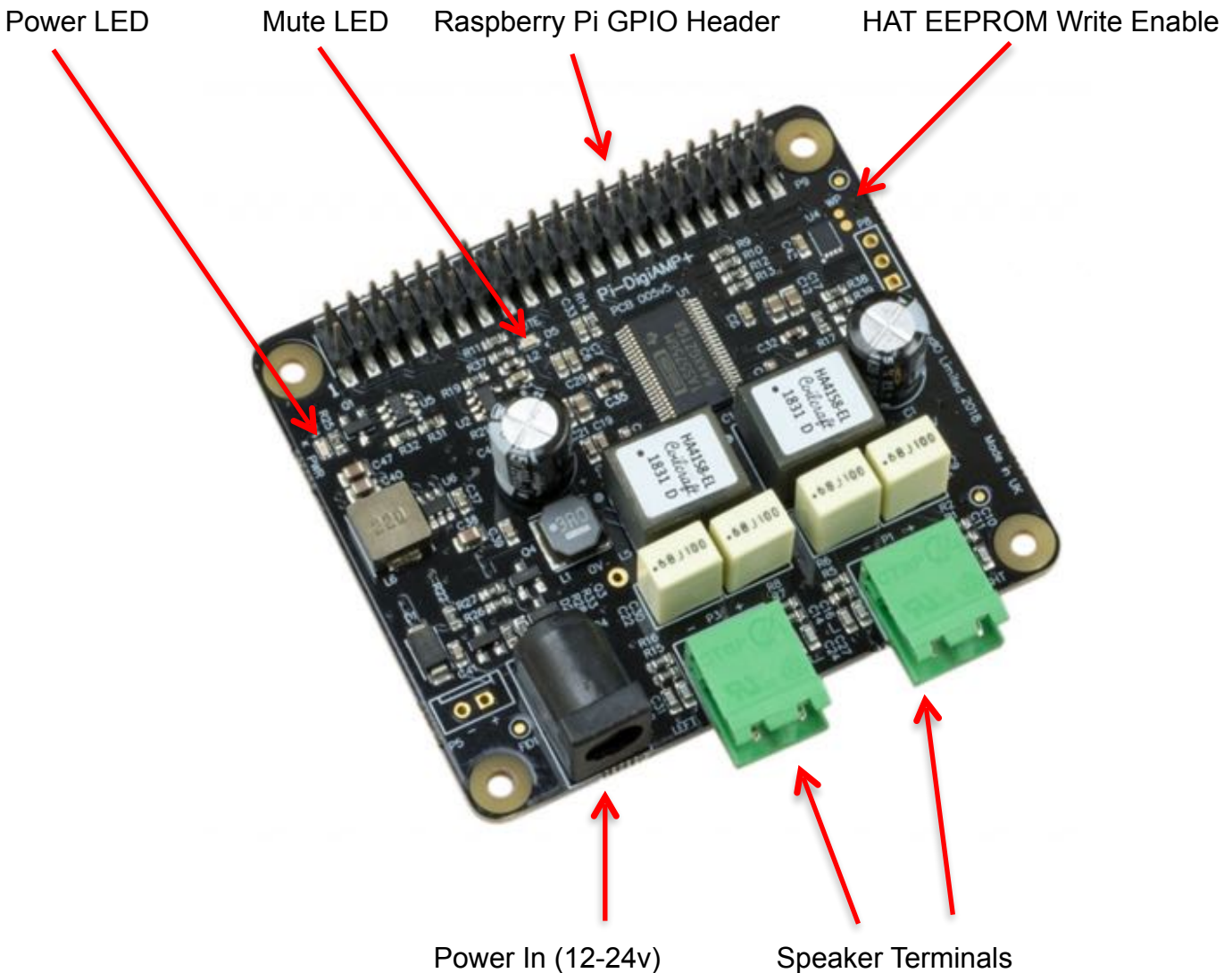

#### 4) The NEW Pi-DAC PRO

The Pi-DAC PRO is a fully HAT compliant add-on accessory for the Raspberry Pi.

The Pi-DAC PRO uses the Texas Instruments PCM5242 to deliver outstanding Signal to Noise Ratio and supports Balanced / Differential out in parallel to Phono / RCA line level output. It also includes the IQaudIO Headphone amp.

The Pi-DAC PRO can be connected to the Raspberry Pi A+/B+/RPi2 or RPi3's 40way pin header without any additional soldering. The Pi-DAC PRO is powered from the Raspberry Pi.

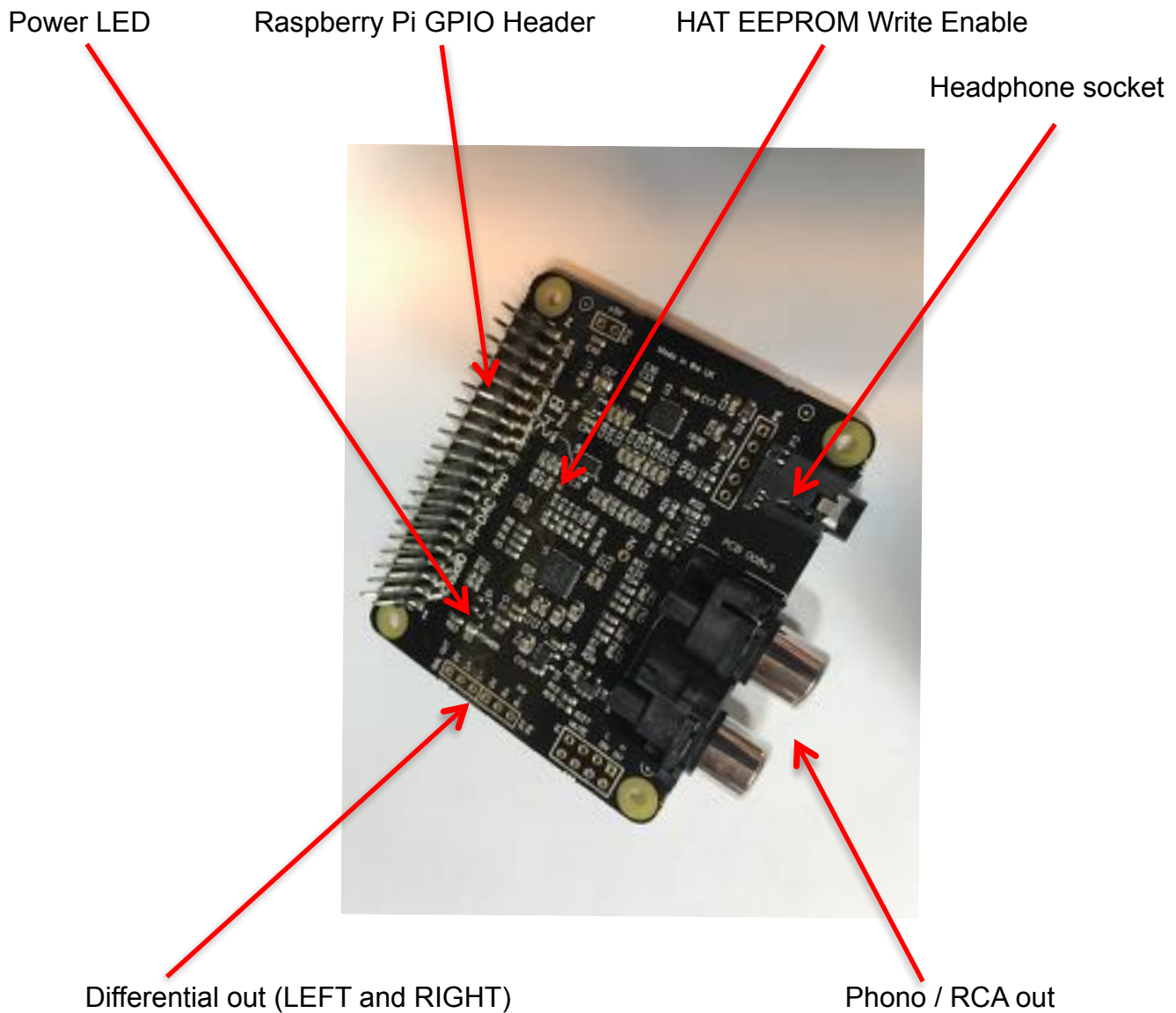

## 5) The Pi-AMP+ (Legacy product)

The Pi-AMP+ is an add-on accessory for the Legacy Pi-DAC+ / Pi-DAC PRO and Raspberry Pi.

The Pi-AMP+ takes the variable output analog audio from the Pi-DAC+ and through the onboard Texas Instruments TPA3118D2 Class D amplifier delivers audio to the Pi-AMP+'s speaker terminals delivering up to 2x35w@19v input.

The Pi-AMP+ requires a 12–19volt power source to operate. Power should be applied via the Pi-AMP+'s standard barrel connector or the two pin JST socket provided.

The Pi-AMP+, when powered, has been designed to provide power to the Raspberry Pi / Pi-DAC+ and Pi-AMP+ combination safely. You can continue to use your Pi devices without risk of damage. As with the Pi-DAC+, we've focused on the components selected and the attention to audio performance during PCB layout when developing the Pi-AMP+.

The Pi-AMP+ is by default muted at power on (mute LED lit). Mute state / LED is under software control (Raspberry Pi GPIO22) but mute may be overridden by shorting the Pi-AMP+'s P9 pins with a suitable jumper – note the mute LED will remain lit if P9 is shorted.

Pi Power out

12v-19v Power In

Speaker Terminals

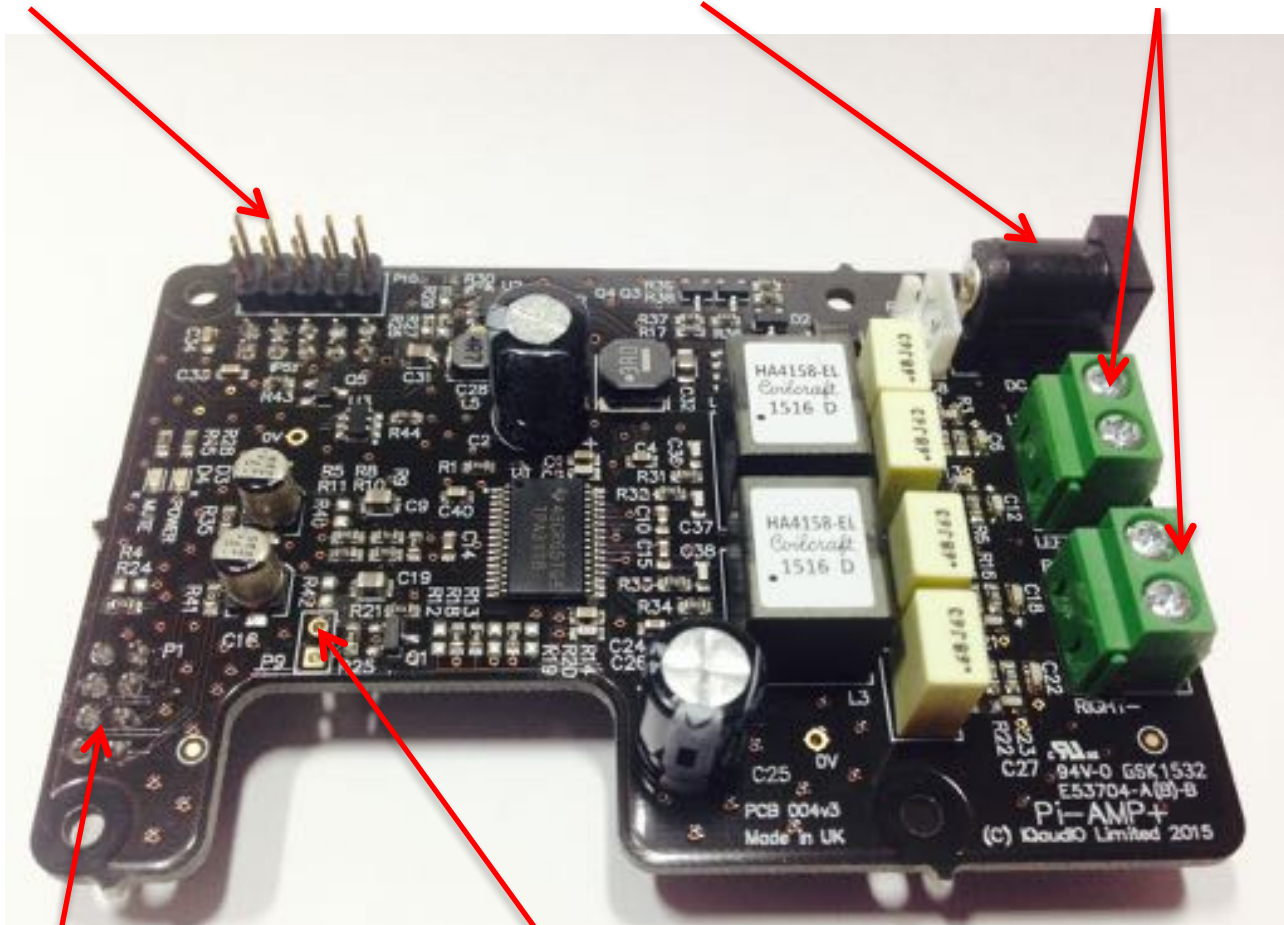

Audio In (from Pi-DAC+)

Mute Override (P9)

## 6) Pi-Digi+

The Pi-Digi+ is a fully HAT compliant add-on accessory for the Raspberry Pi.

The Pi-Digi+ takes the digital audio signals (I2S) from the Raspberry Pi and through the onboard Wolfson / Cirrus Logic WM8804 delivers Optical TOSLINK and isolated electrical SPDIF connection to an external DAC.

The Pi-Digi+ can be connected to the Raspberry Pi A+/B+/RPi2 or RPi3's 40way pin header without any additional soldering. The Pi-Digi+ is powered from the Raspberry Pi.

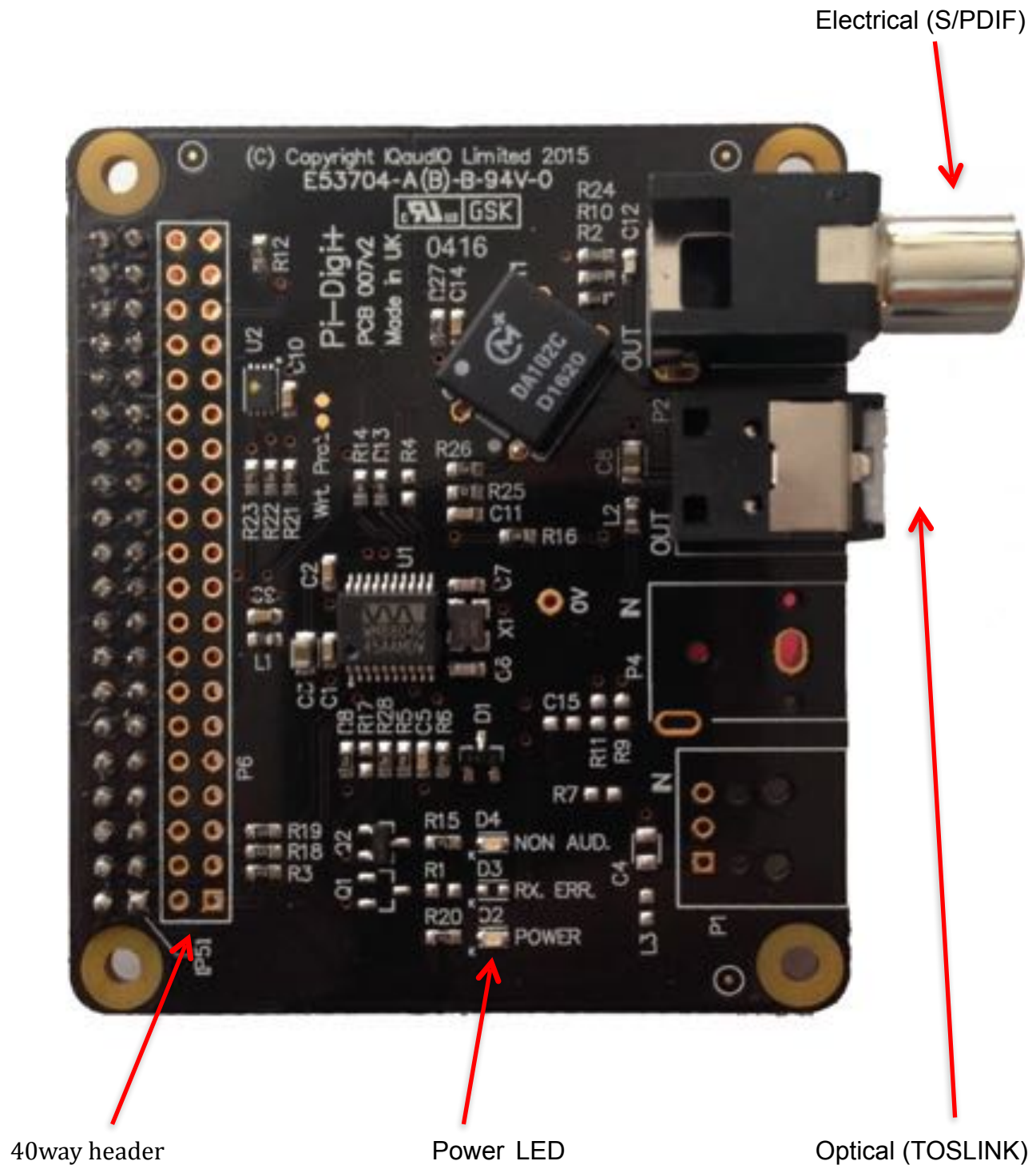

## 7) The Pi-DACZero / DACZeroHeadphone

The Pi-DACZero is a smaller version of the IQaudio Pi-DAC+ which is designed to be used with the Raspberry Pi-Zero.

The Pi-DACZero delivers audio Line Out and uses the same Linux drivers as the Pi-DAC+.

There is an optional Headphone daughter card for the Pi-DACZero which can be mounted above the DACZero to give an amplified headphone output in parallel. The Pi-DACZero and Pi-DACZeroHeadphone boards are powered from the Raspberry Pi-Zero itself.

Rotary Encoder Header (P3) Pin1:GPIO23, Pin2:GROUND, Pin3:GPIO24

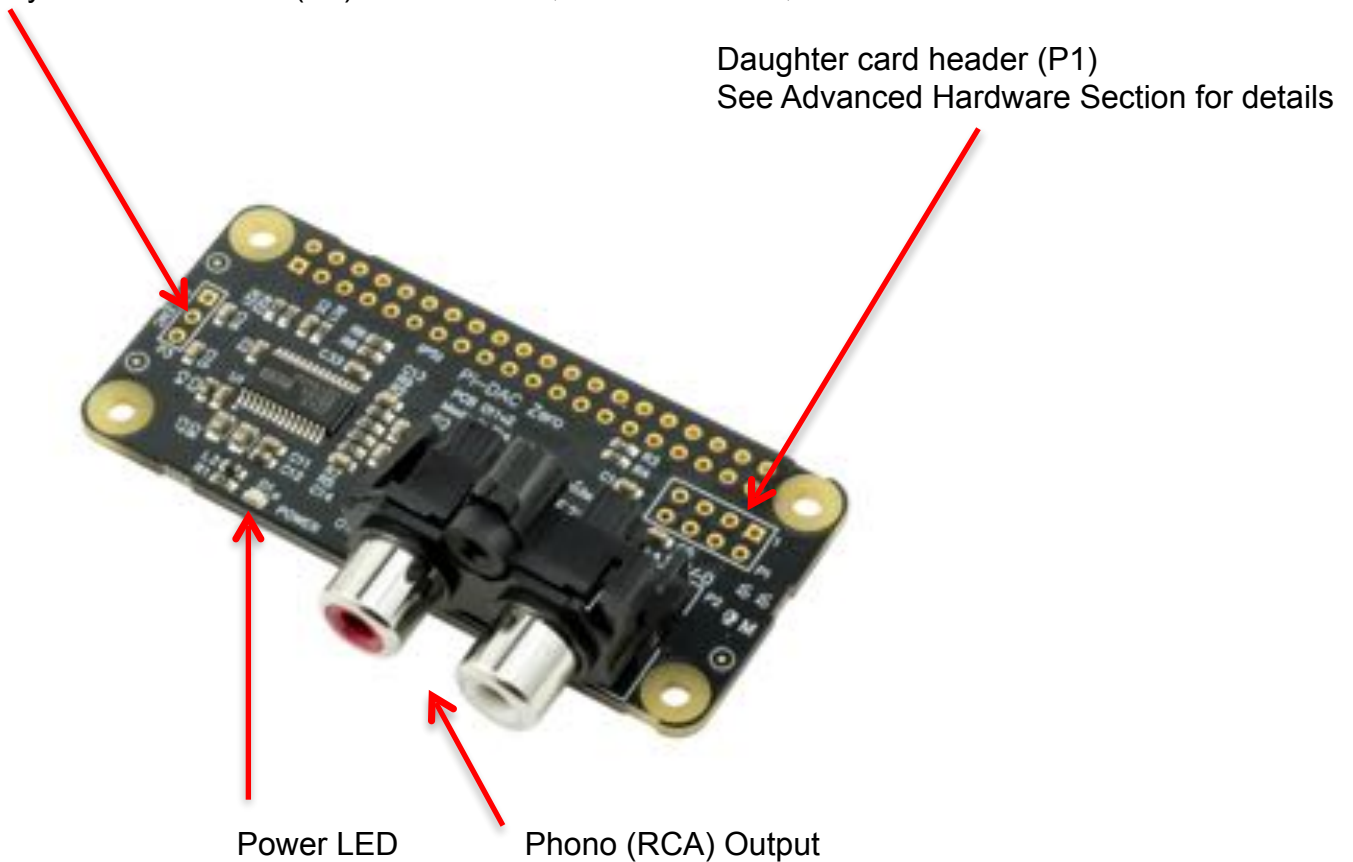

### DACZero Headphone

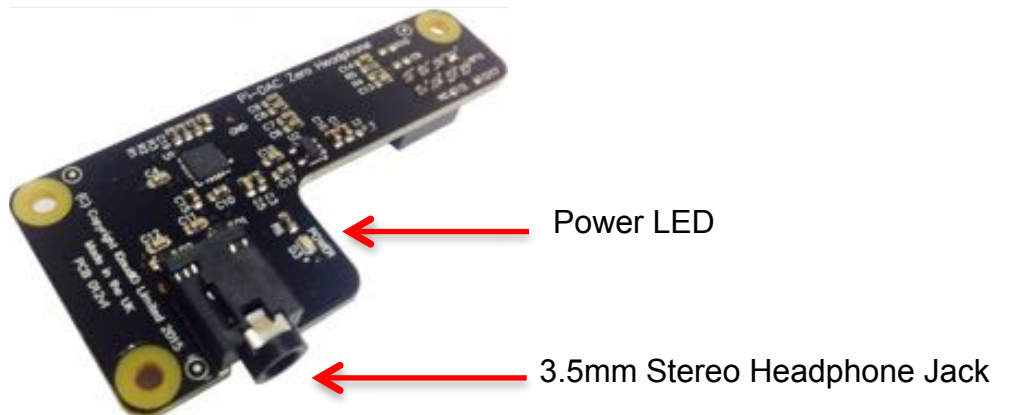

## 8) Connecting the Pi-DAC+ to your Raspberry Pi

**WARNING: PLEASE ENSURE ALL CABLES ARE DISCONNECTED FROM THE Pi-DAC+ AND THE RASPBERRY PI BEFORE ATTEMPTING THIS PROCEDURE.**

The Pi-DAC+ can be connected to the Raspberry Pi's 40way pin header without any additional soldering.

The Pi-DAC+ is normally supplied\* along with 4x 12mm PCB spacers and 8x M2.5 screws. You may want to use a 30way right-angled I/O pin header (only needed if you wish to use the exposed Raspberry Pi GPIO).



The spacers should be screwed (finger tight only) to the Raspberry Pi before adding the Pi-DAC+.

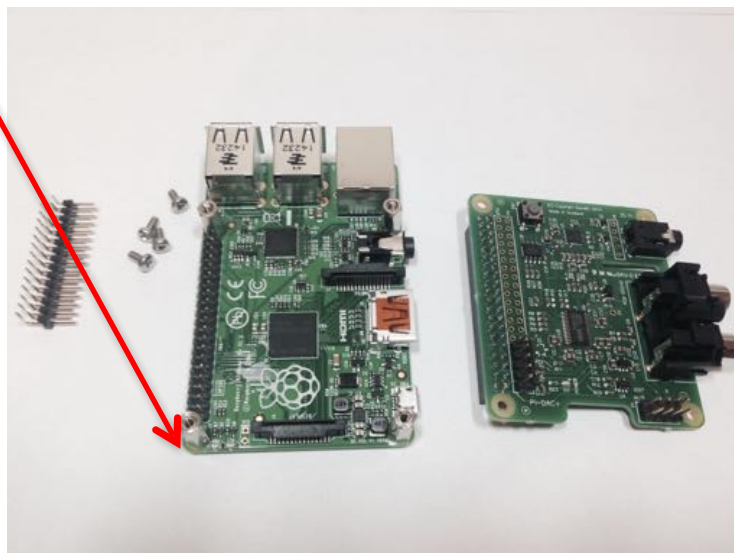

Once the Pi-DAC+ has been fitted the remaining screws can be tightened (finger tight please) as required.

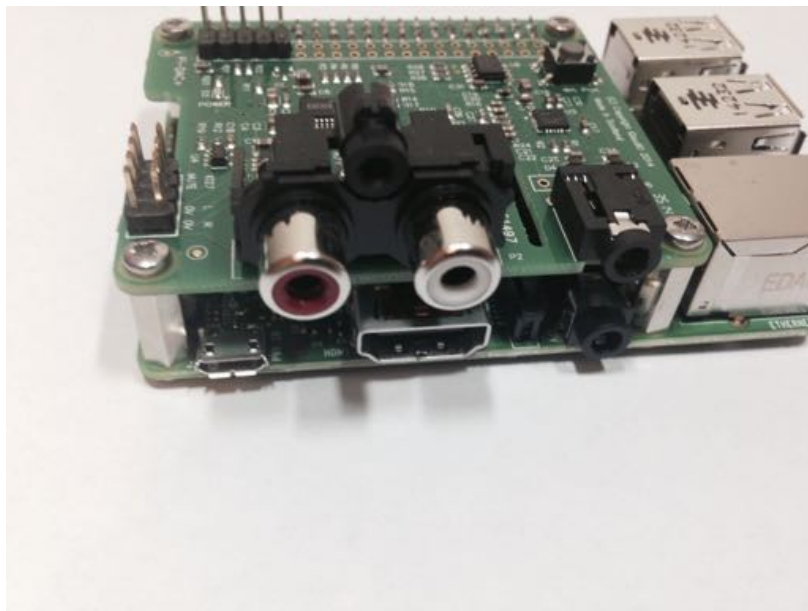
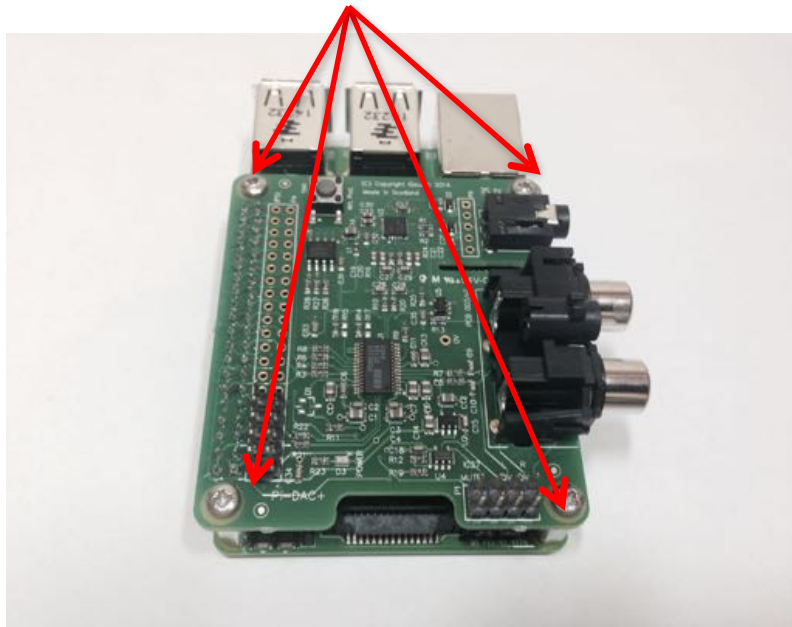

If you are using the Pi-CASE+ then replace the 4x screws beneath the Pi with the 4x 5mm PCB standoffs provided with the Pi-CASE+

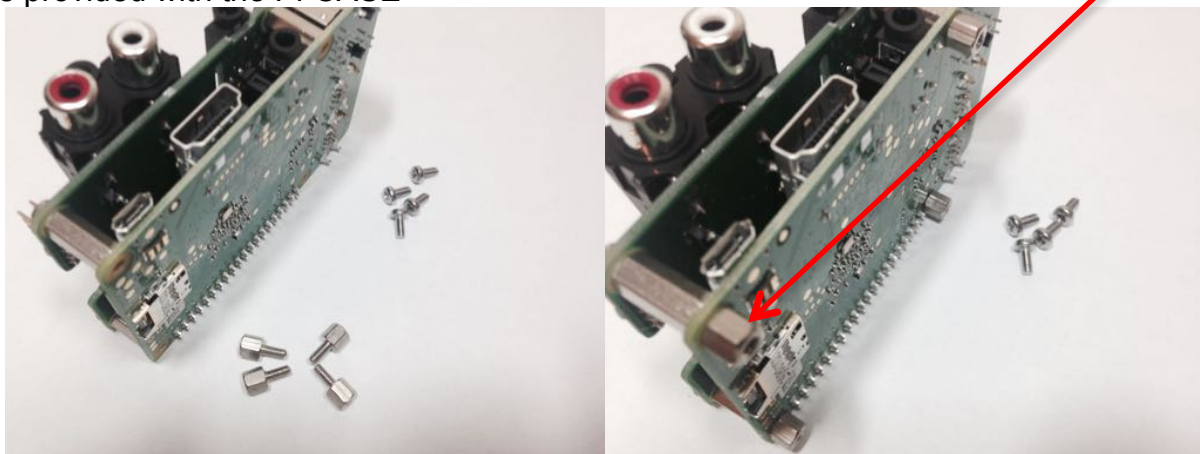

Apply power to your Raspberry Pi in the normal way. You should see that the Raspberry Pi and the Pi-DAC+ both have power LEDs – this indicates that the power is successfully being applied to the Pi-DAC+.

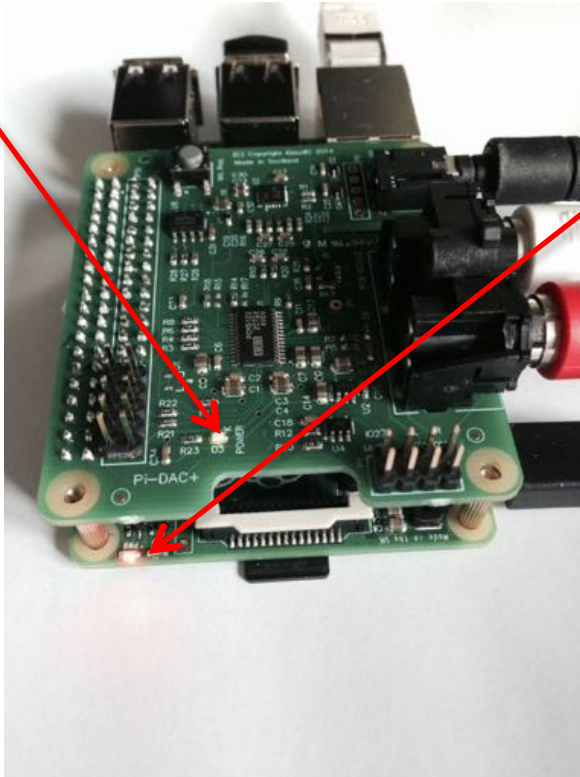

You can now remove power and reconnect any necessary peripherals.



## 9) Connecting the Pi-DigiAMP+ to your Raspberry Pi (Pictures are of LEGACY product)

**WARNING: PLEASE ENSURE ALL CABLES ARE DISCONNECTED FROM THE Pi-DigiAMP+ AND THE RASPBERRY PI BEFORE ATTEMPTING THIS PROCEDURE.**

The Pi-DigiAMP+ can be connected to the Raspberry Pi's 40way pin header without any additional soldering.

The Pi-DigiAMP+ is supplied\* along with 4x 12mm PCB spacers and 8x M2.5 screws.

The spacers should be screwed (finger tight only) to the Raspberry Pi before adding the Pi-DigiAMP+.

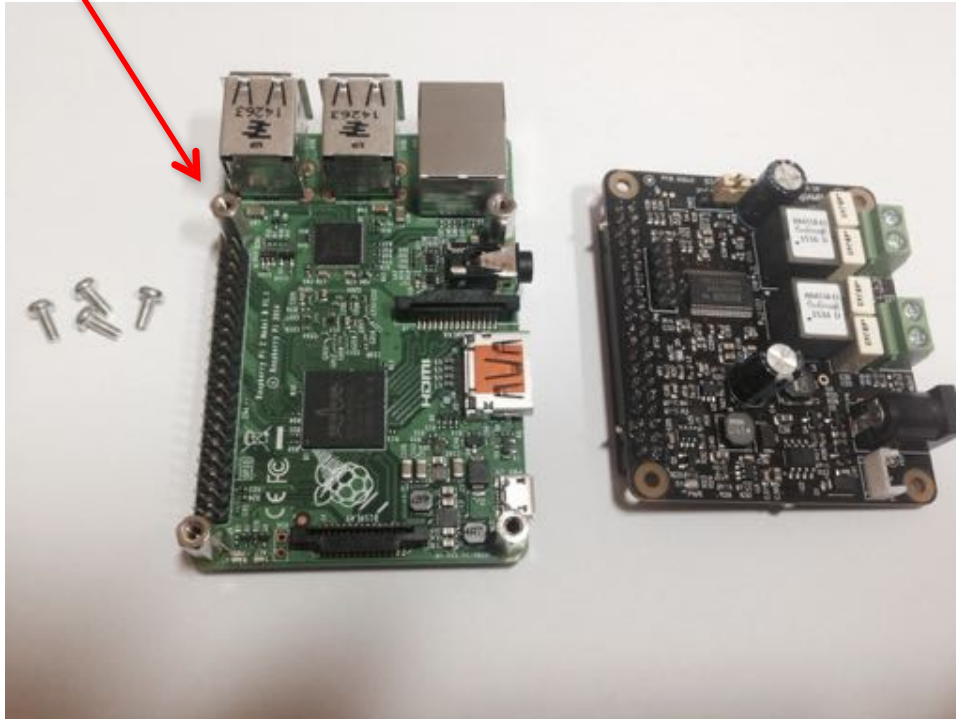

Once the Pi-DigiAMP+ has been fitted the remaining screws can be tightened (finger tight please) as require

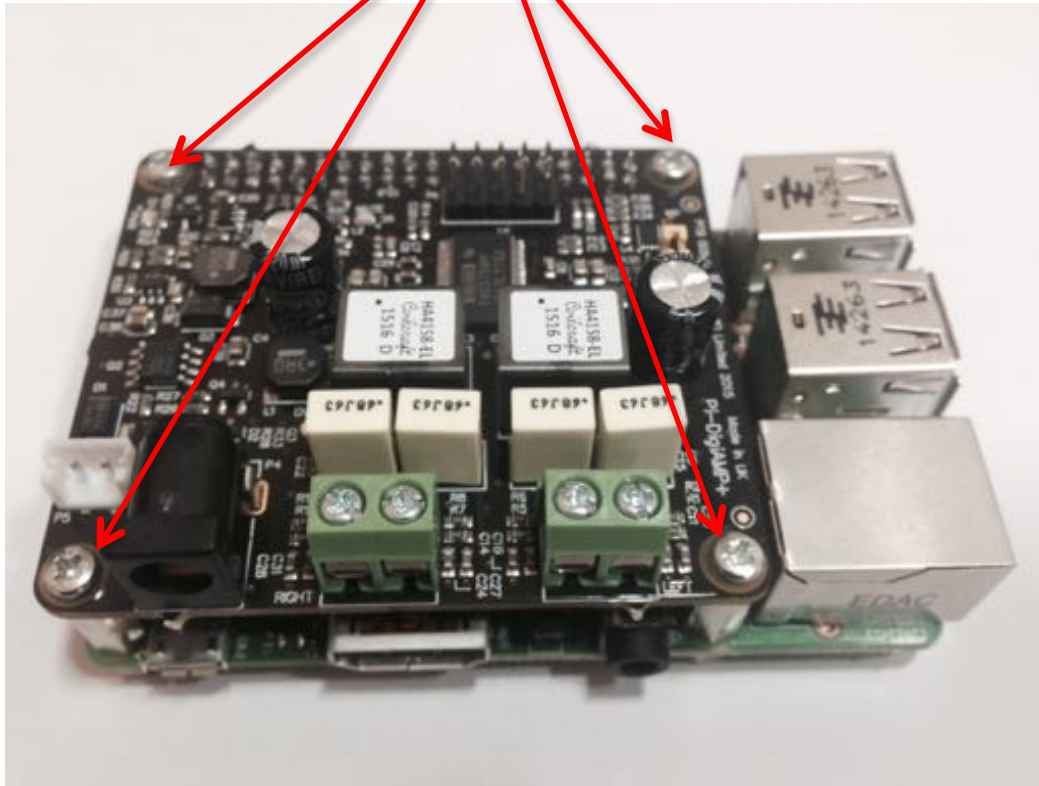

If you are using the Pi-CASE+ then replace the 4x screws beneath the Pi with the 4x 5mm PCB standoffs provided with the Pi-CASE+

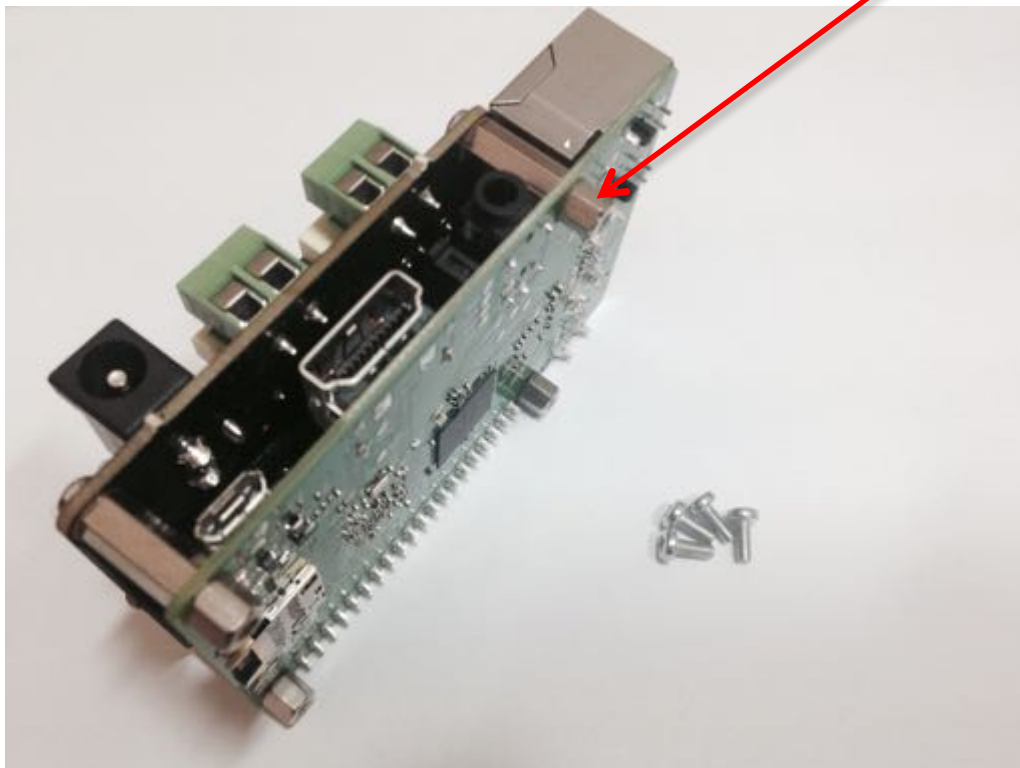

## DO NOT APPLY POWER TO YOUR RASPBERRY PI VIA THE PI'S MICRO USB SOCKET.

The Pi/Pi-DigiAMP+ combination **MUST** be powered via the Pi-DigiAMP+, not the Raspberry Pi. Once you are happy with that the Raspberry Pi and Pi-DigiAMP+ are connected correctly you are nearly ready to apply power.

Power should only be applied to the Pi-DigiAMP+ once speakers have been attached. Powering the Pi-DigiAMP+ without speakers attached may damage the device.

The Pi-DigiAMP+ has been designed to be powered by the recommended XP Power DC supply. The Power supply's output connector should be inserted into the Pi-DigiAMP+'s DC input terminal (marked P4). Only then should the Power supply's AC input be plugged into the mains.

When power has been applied to the Pi-DigiAMP+ it will also provide power to the Raspberry Pi. You should see that the Raspberry Pi and the Pi-DigiAMP+ both have power LEDs – when both are lit it indicates that the power is successfully being applied to the Pi-DigiAMP+ and Pi. The Pi-DigiAMP+'s Mute LED will also be lit.

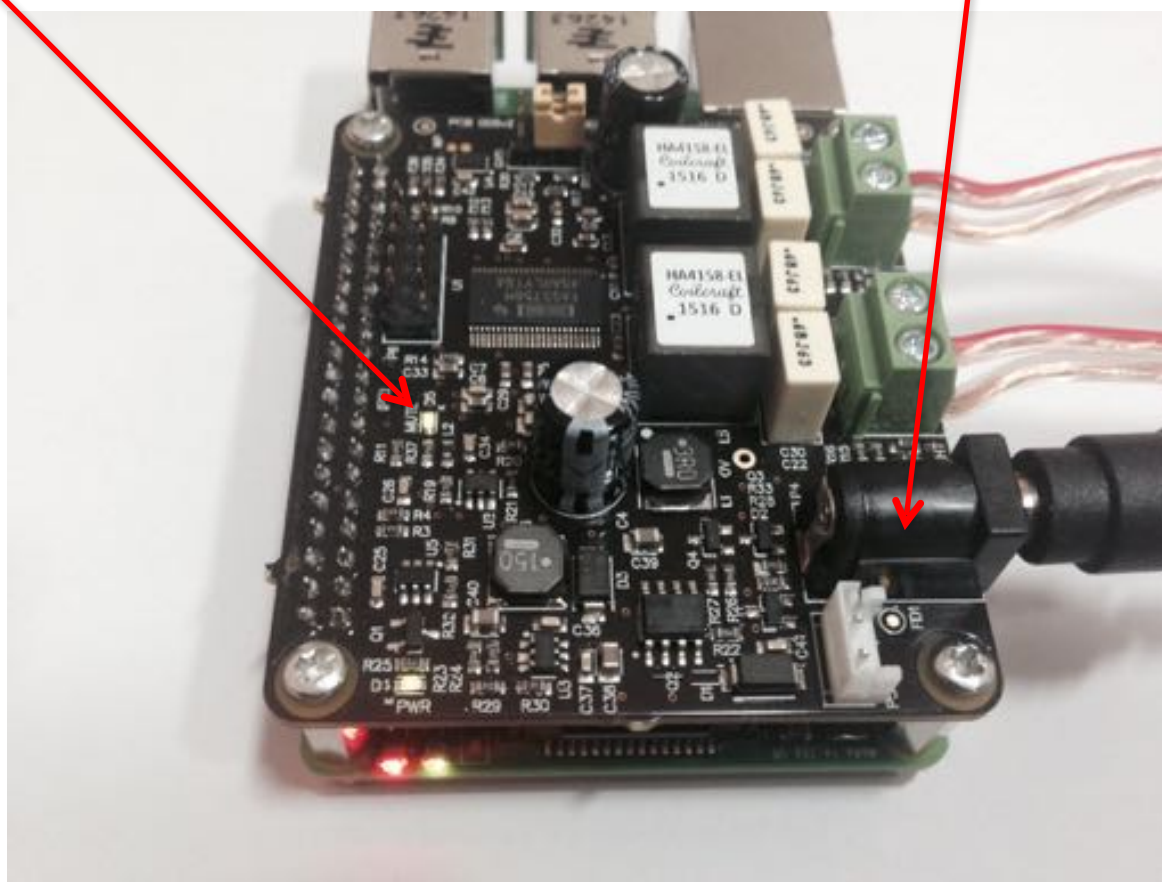

You can now remove power and reconnect any necessary peripherals, install in case etc.

For accurate performance, your loudspeakers must be connected in phase. For both left and right loudspeakers.

P3 is for connecting the RIGHT speaker

P1 is for connecting the LEFT speaker

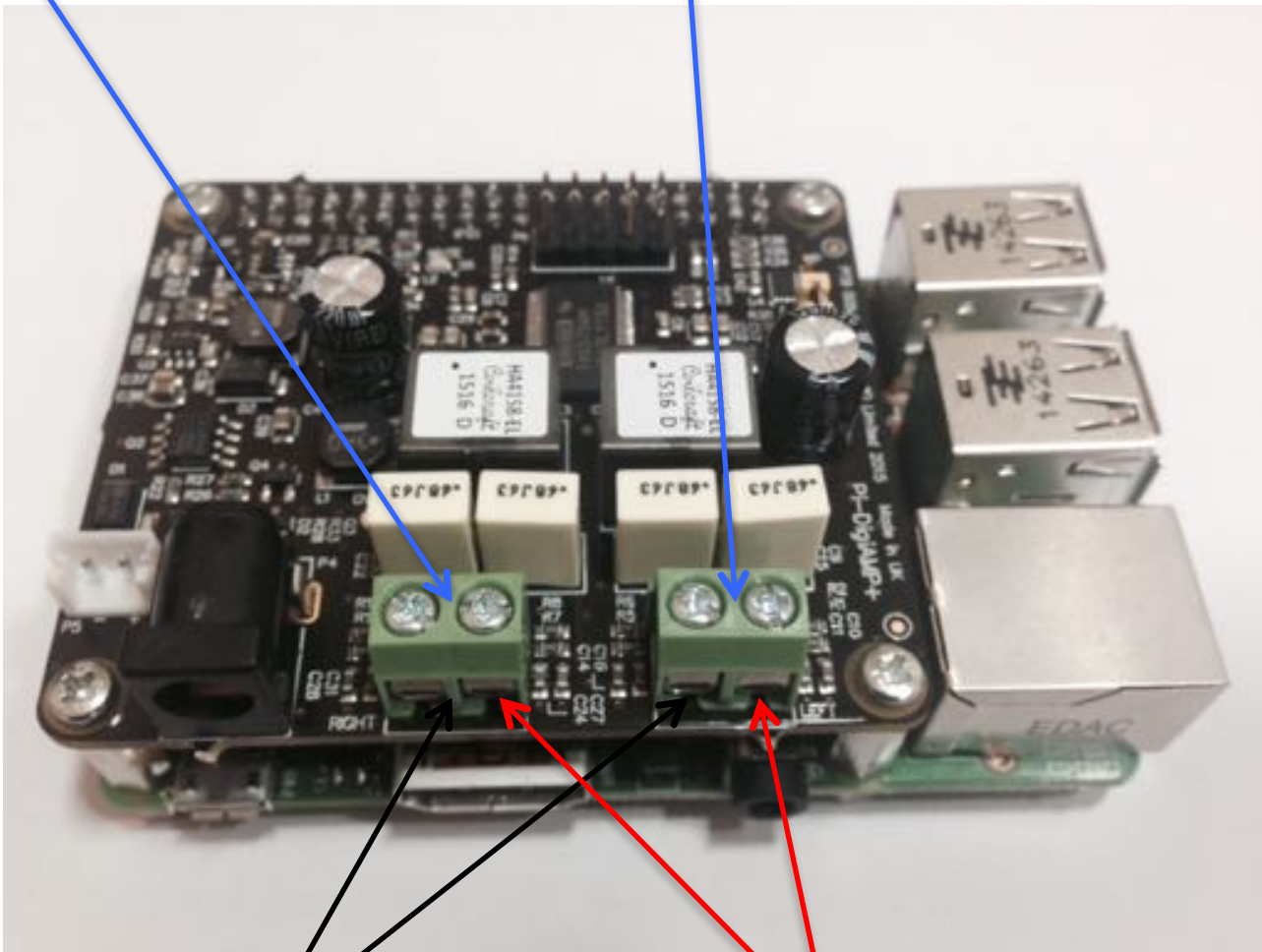

Attach the speaker -ve terminal (often black) to the - on the amplifier output

Attach the speaker +ve terminal (often red) to the + on the amplifier output

Now select the output gain +20db or +26db by selecting the appropriate pin header position on P7. Selecting +26db will result in louder volume overall but it also slightly increases the THD+N (Total Harmonic Distortion plus Noise) figure and noise floor. **DO NOT MOVE THIS PIN WHEN POWER IS APPLIED.**

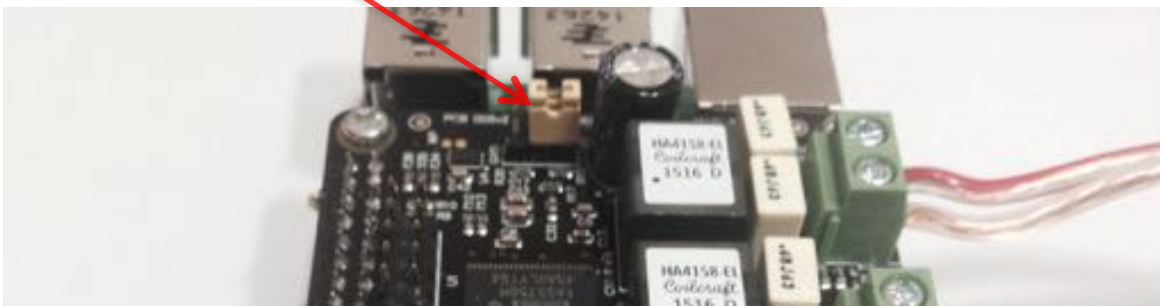

## 10) Connecting the Pi-AMP+ to your Pi-DAC+ (Pictures are of LEGACY product)

**WARNING: ENSURE YOU HAVE DISCONNECTED ALL POWER BEFORE ATTEMPTING THIS PROCEDURE**

The Pi-AMP+ connects to the Pi-DAC+ through both Pi-DAC+'s two pin headers (the 2x4 audio pin header, and the 2x5 power header).

NOTE: Older Pi-DAC+ may not have the 2x5 power header fitted. Please see Section 10 for details on how to solder this to the Pi-DAC+ before continuing.

The Pi-AMP+ is supplied\* with 4x male/female 12mm M2.5 PCB spacers. Use these spacers to attach the Pi-DAC to the Raspberry Pi.

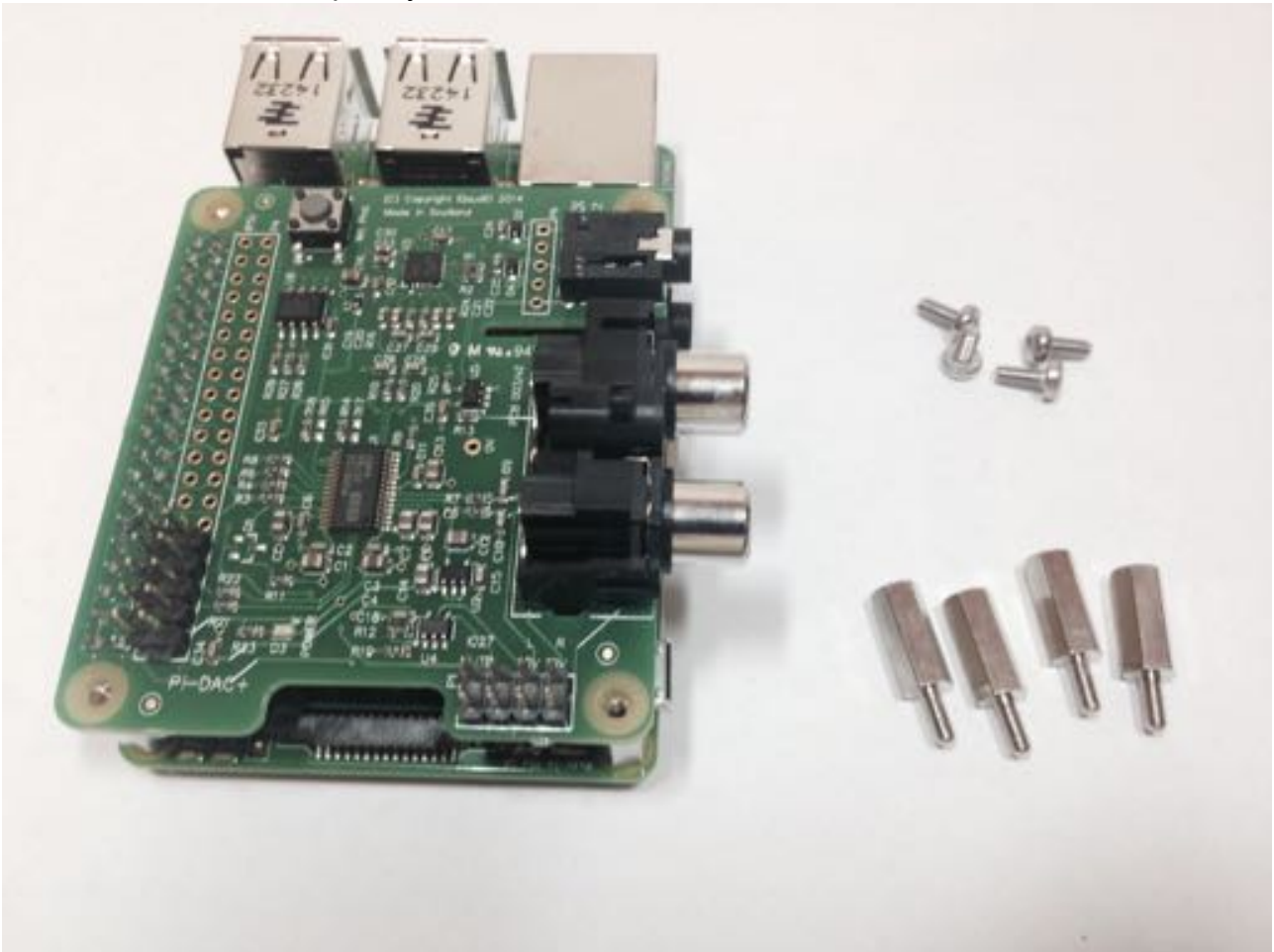

The male/female spacers should replace the 4 screws (these should be retained) previously used to secure the Pi-DAC+ to the Raspberry Pi.

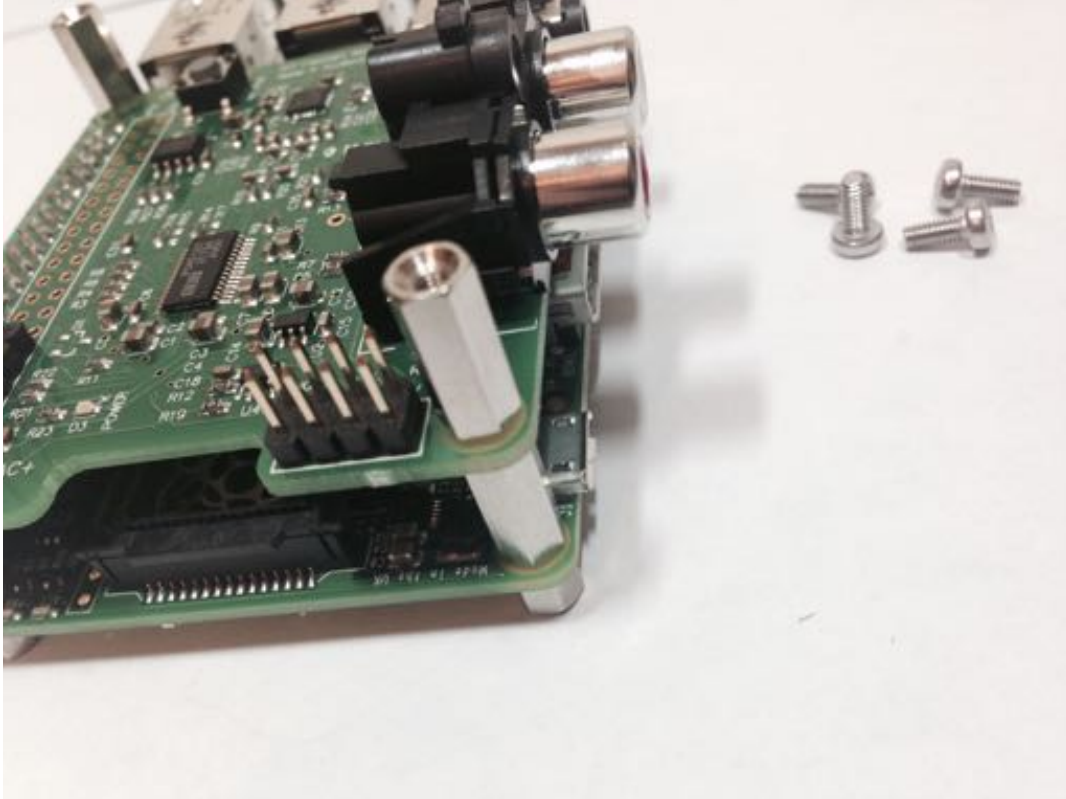

Once the Pi-AMP+ has been fitted the remaining screws (from the Pi-DAC+) can be tightened (finger tight is fine) as required to secure the full PCB stack.

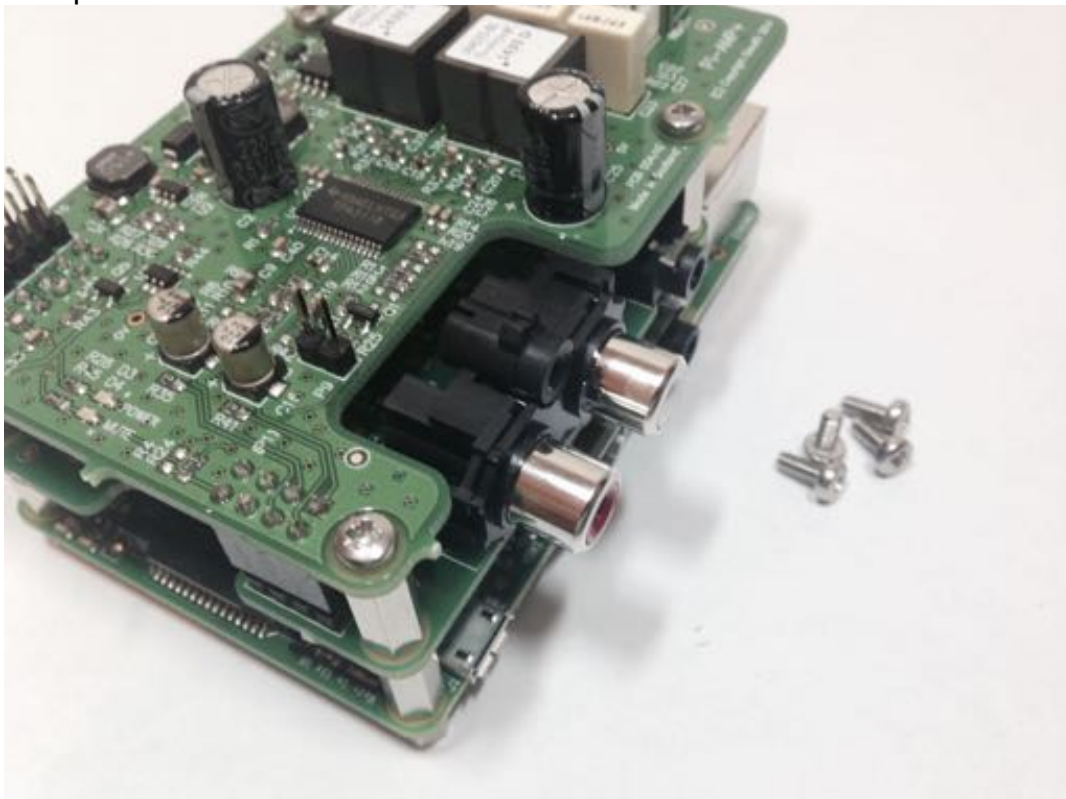

**DO NOT APPLY POWER TO YOUR RASPBERRY PI VIA THE PI'S MICRO USB SOCKET.**

The Pi/DAC+/AMP+ combination **MUST** be powered via the Pi-AMP+, not the Raspberry Pi. Once you are happy with that the Raspberry Pi / DAC+ and AMP+ are connected correctly you are ready to apply power.

The Pi-AMP+ combination is designed to be powered by the recommended XP Power DC supply. The Power supply's output connector should be inserted into the Pi-AMP+'s DC input terminal (marked "+15V power"). Only then should the Power supply's AC input be plugged into the mains.

Once power is applied via the Pi-AMP+ you should see that the Raspberry Pi the Pi-DAC+ and the Pi-AMP+ have their power LEDs illuminated – this indicates that the power is successfully being applied to each board as expected. The Pi-AMP+'s Mute LED will also be lit.

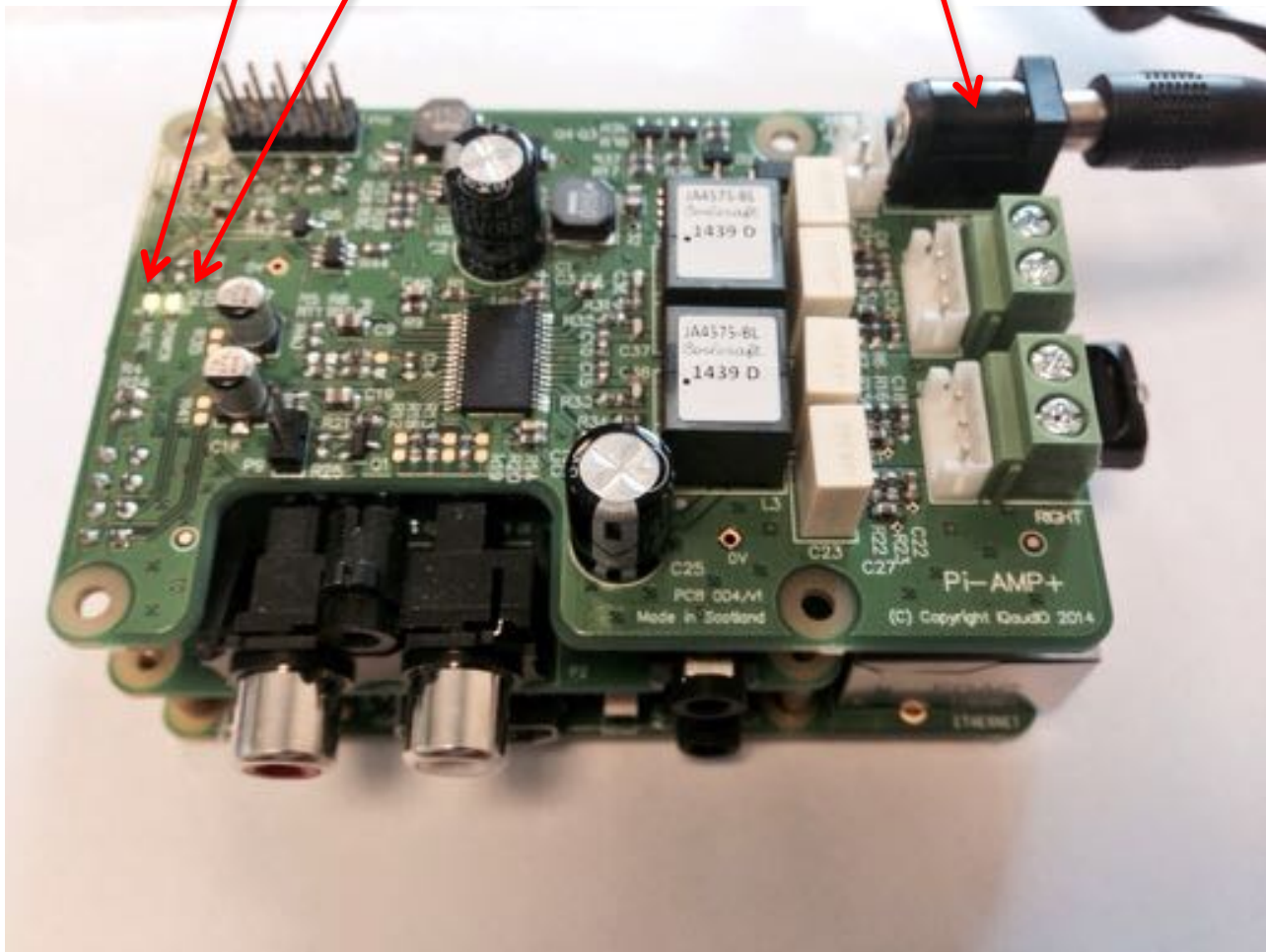

You can now remove power and reconnect any necessary peripherals you may need, including speakers.

**NOTE:** **ALWAYS** remove power **BEFORE** connecting speaker cable to the Pi-AMP+

For accurate performance, your loudspeakers must be connected in phase. For both left and right loudspeakers.

P3 is for connecting the RIGHT speaker

P2 is for connecting the LEFT speaker

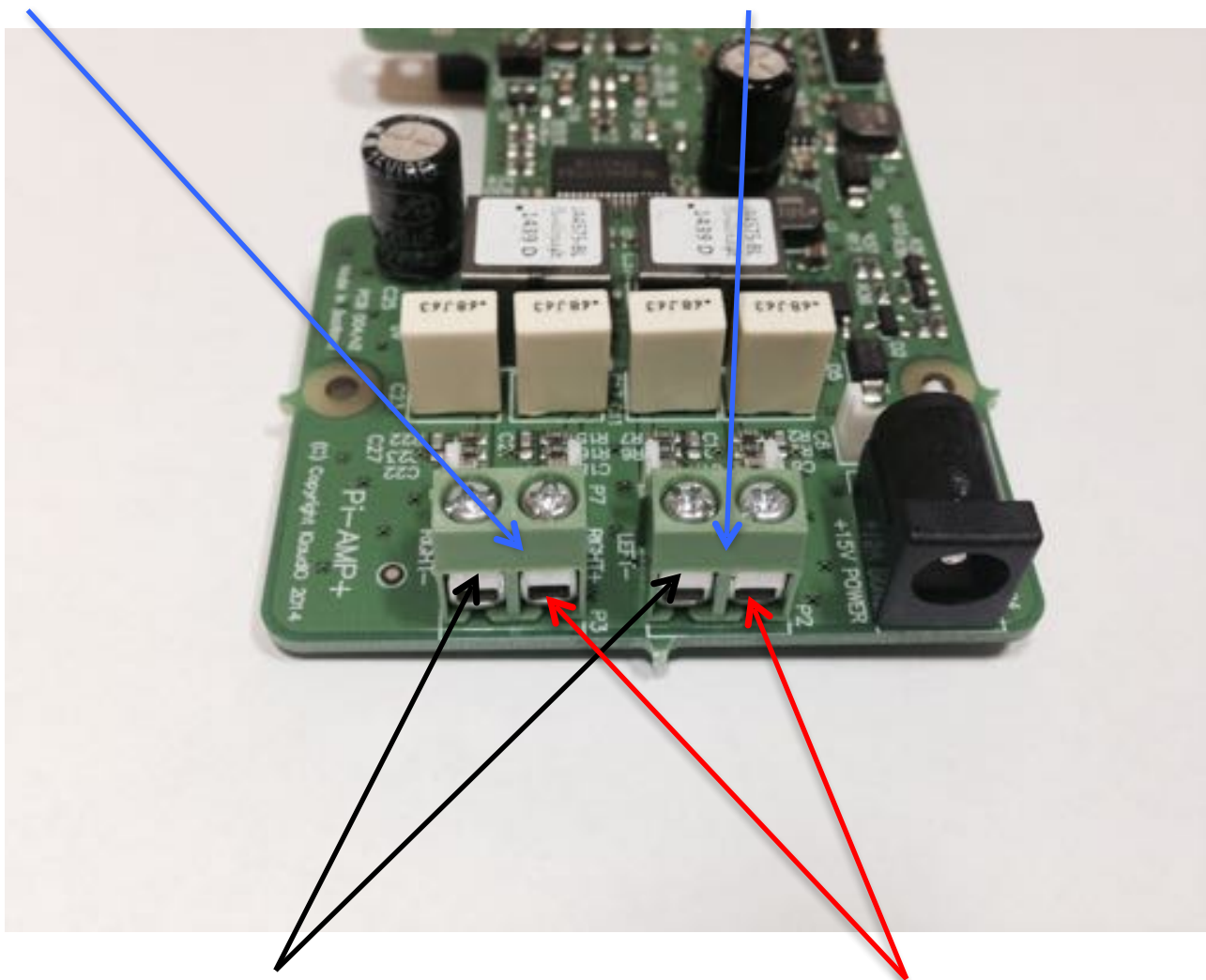

Attach the speaker -ve terminal (often black) to the - on the amplifier output  
Attach the speaker +ve terminal (often red) to + on the amplifier output



## 11) Building the Raspberry Pi and IQaudIO sound cards into your Pi-CASE+

The following may prove helpful when building your Raspberry Pi and IQaudIO sounds card into the appropriate Pi-CASE+.

All acrylic CASE+ installations follow the same process:

- **If there is a protective film applied to either side of your acrylic, remove it now.** If you build the CASE+ whilst retaining the protective film you may find that the finished look is spoilt or for transparent cases, the result may be opaque.
- Bolt the PCBs together before attempting to install the bundle in the case. Make sure the small 5mm female/male spacers are fitted to the bottom of the Raspberry Pi
- Build the case sides around the PCB first (tip: use tape on each corner during the build process)
- Add the bottom and top
- Add the bolts and small rubber bumper stickers

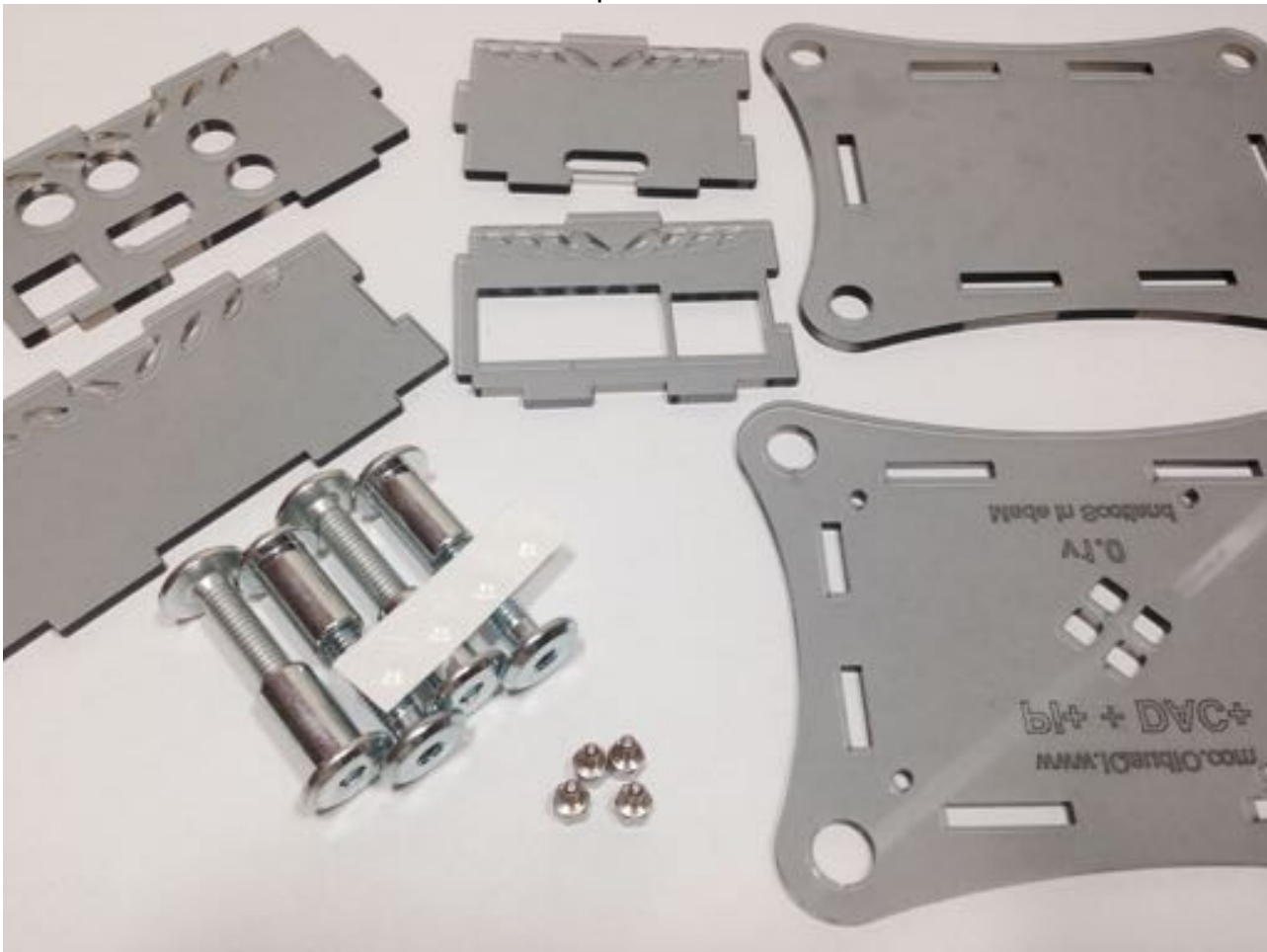

a) Lay out the CASE+ sides corresponding to the Raspberry Pi / Pi-DAC+ / Pi-DigiAMP+ / Pi-AMP+



b) Then, build the sides up around the Raspberry Pi. Use sticky tape at each corner to make things simpler to assemble.

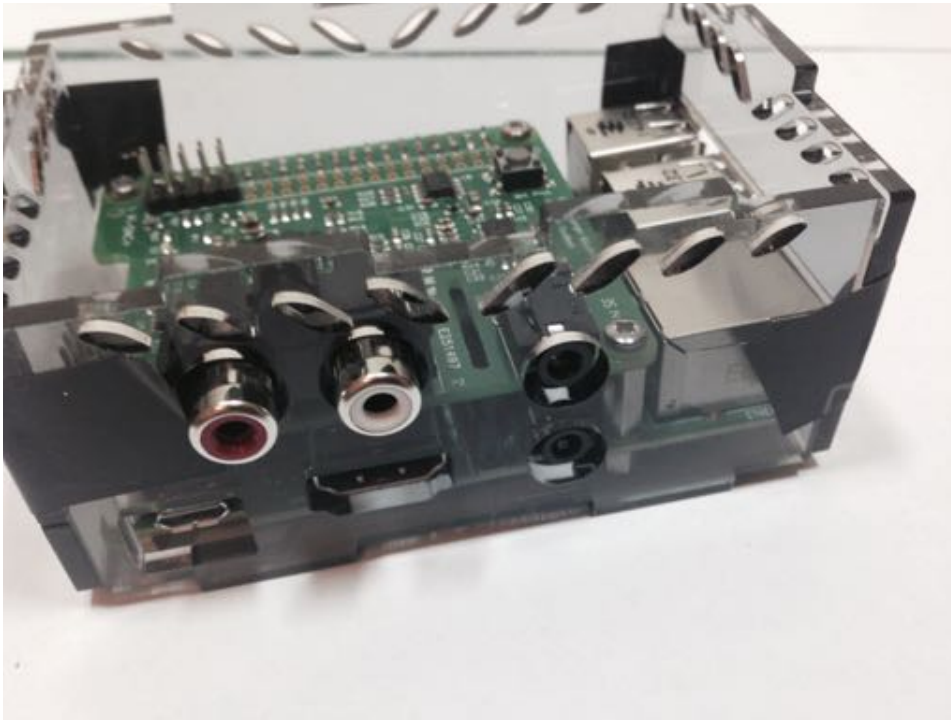

c) Add the base (with text outwards) and screw the case to the Raspberry Pi



d) If you are building the CASE+ for Pi-DigiAMP+ or Pi-AMP+ then now is the time to secure the speaker cables before fitting the top.

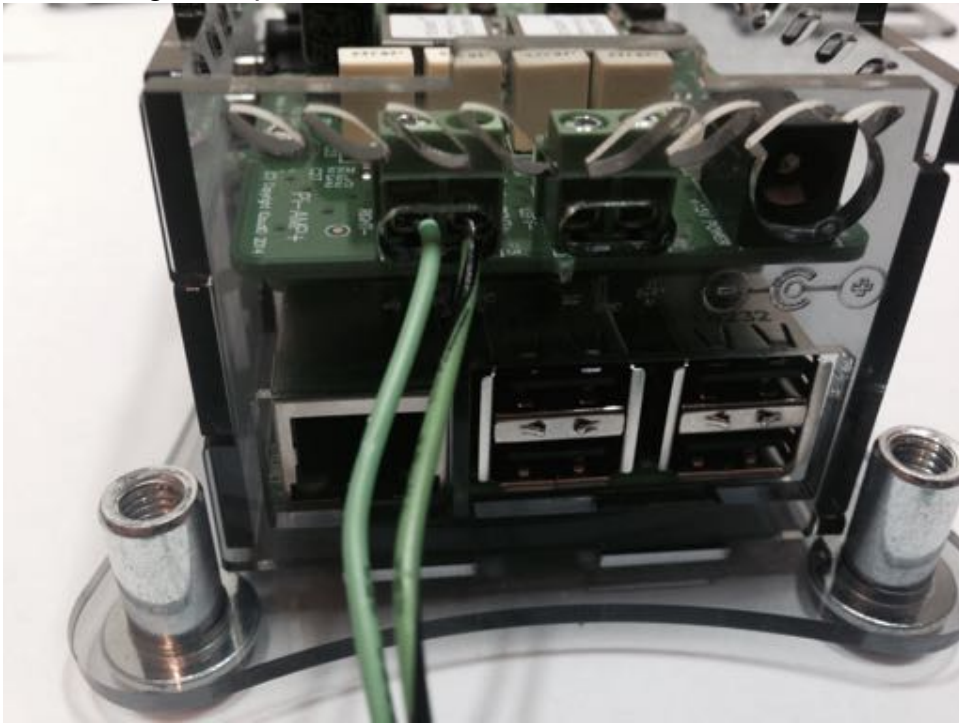

e) Pi-CASE+ top in place



Now add the 4 nuts and bolts – Do not over tighten, finger tight is OK

f) Completed Pi-CASE+ with Raspberry Pi and Pi-DAC+ inside



g) Now apply the small transparent bumper stickers to the base of each Bolt.



h) Now to complete screw the remaining 4 screws from the bottom of the case into the 5mm spacers inside.



NOTE: Access to the Raspberry Pi micro SD card can be tricky due to the width of the Perspex. We suggest the use of tweezers.

The CASE+ for DAC+ and Raspberry Pi A+



The CASE+ for DAC+ / Pi-DigiAMP and Raspberry Pi B+

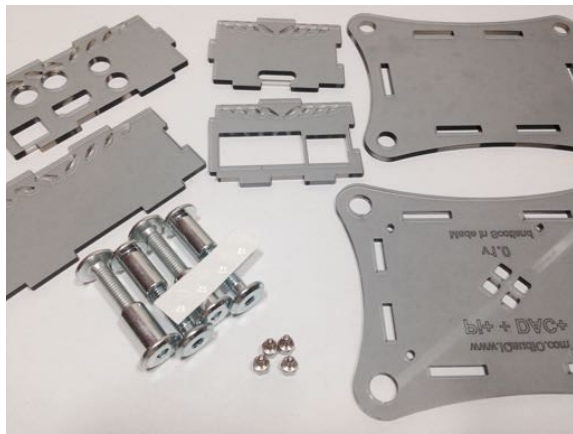

The CASE+ for DAC+ / AMP+ and Raspberry Pi B+

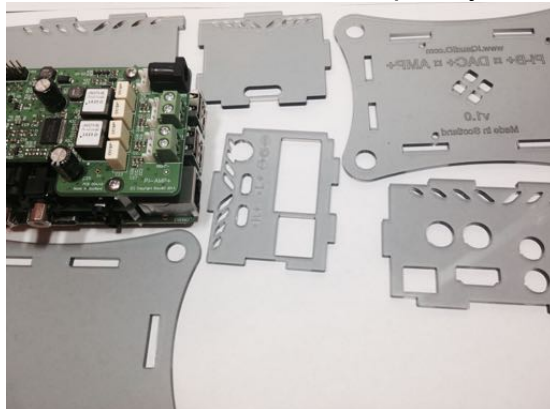

## 12) Configuring Raspbian to include sound card support

This section covers the use of DeviceTree based driver support – as used in the Raspbian releases from late 2015. The new range of IQaudIO boards come with programmed EEPROMS. This negates the need to modify the Raspbian configuration.

Note - Some pre-configured popular audio applications with IQaudIO sound card support are available to download from [www.iqaudio.com/downloads](http://www.iqaudio.com/downloads).

If you would rather configure your already downloaded OS then the following stems will help...

This guide assumes you are using the standard Raspbian (Debian Wheezy or later) distribution from here: <http://www.raspberrypi.org/downloads/> and that you have an SD card flashed with Raspbian and have a login to your Raspberry Pi (either local or via ssh). You should have also run raspi-config and expanded the filesystem to occupy your full SD card.

- Update Raspbian on the SD card to be the latest available.  
pi@raspberrypi ~ \$ sudo rpi-update  
pi@raspberrypi ~ \$ sudo apt-get update  
pi@raspberrypi ~ \$ sudo apt-get dist-upgrade
- To ensure that the IQAUDIO Device drivers are loaded make sure /boot/config.txt file has the valid entry below.
  - a. For Pi-DAC+, Pi-DACZero, Pi-DAC Pro and Pi-DigiAMP+ use the iqaudio-dacplus
  - b. For Pi-Digi+, use iqaudio-digi-wm8804-audio

```
pi@raspberrypi ~ $ sudo nano /boot/config.txt
```

```
dtoverlay=iqaudio-dacplus
```

or

```
dtoverlay=iqaudio-digi-wm8804-audio
```

From Raspbian 4.4.14+ onwards it is also possible to control any of the IQaudIO AMP modules “mute state” from the config.txt file with additional optional parameters:

```
dtoverlay=iqaudio-dacplus,unmute_amp
```

This will give a "one-shot" unmute when kernel module loads.

```
dtoverlay=iqaudio-dacplus,auto_mute_amp
```

This will unmute the amp when ALSA device opened by a client. Mute, with 5 second delay when ALSA device closed. (Re-opening the device within the 5 second close window, will cancel mute.)

- To remove the standard Raspberry PI audio card, comment out the {dtparam=audio=on} device tree parameter in your /boot/config.txt and reboot.  
pi@raspberrypi ~ \$ sudo nano /boot/config.txt  
# Enable audio (loads snd\_bcm2835)  
#dtparam=audio=on
- Flush your filesystem changes and reboot the Raspberry Pi  
pi@raspberrypi ~ \$ sync  
pi@raspberrypi ~ \$ sudo reboot

Once restarted SSH into the Pi and check that the audio drivers / card is available to ALSA.  
pi@raspberrypi ~ \$ aplay -l

If the IQaudio board and drivers have been installed correctly you should see something similar to:

```
pi@iqaudio ~ $ aplay -l
**** List of PLAYBACK Hardware Devices ****
card 0: IQaudIODAC [IQaudIODAC], device 0: IQaudio DAC HiFi pcm512x-hifi-0 []
  Subdevices: 0/1
  Subdevice #0: subdevice #0
```



### 13) Checking audio is working through the IQaudio sound card

Once support is active using devicetree you should now be able to listen to music.

- Once the Raspberry Pi boots, log in and check that the IQaudio board is visible as an ALSA audio card by running `aplay -l`, the output should be similar to that below. Note the **device** number and **subdevice** number – these may be useful to you when configuring media applications to access the sound card in your system.

```
pi@iqaudio ~ $ aplay -l
**** List of PLAYBACK Hardware Devices ****
card 0: IQaudiODAC [IQaudiODAC], device 0: IQaudio DAC HiFi pcm512x-hifi-0 []
  Subdevices: 0/1
  Subdevice #0: subdevice #0
```

- For Analogue boards (**not the Pi-digi+**), check that you can adjust the volume. From the Raspberry Pi run `alsamixer`. If you have more than one sound card installed you may have to select which is being controlled by pressing the F6 key.

```
pi@raspberrypi ~ $ alsamixer
```

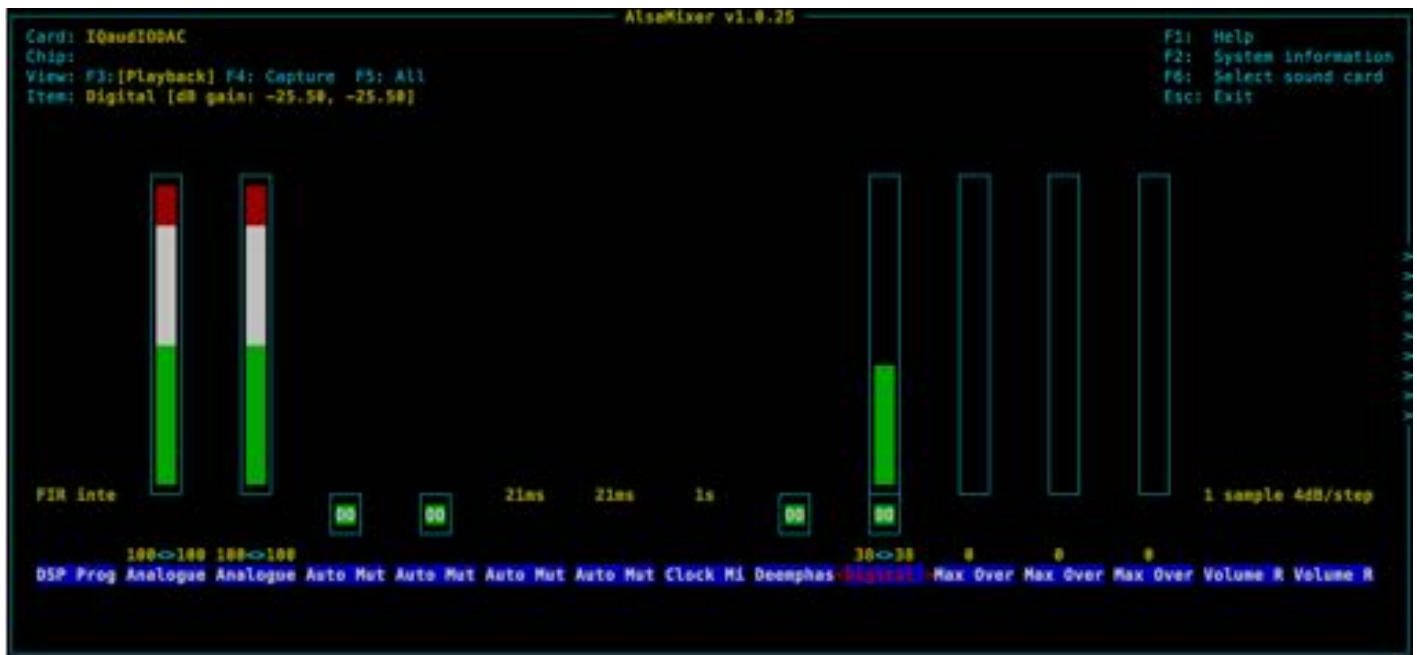

Now adjust the volume by highlighting “Digital” (Press your cursor keys left and right to select) and increase / decrease the volume by pressing your up and down cursor keys. Remember 100% = 0db, 0% is mute!

**NOTE: Both mixers ANALOGUE and ANALOGUE PLAYBACK BOOST should be set to 100%**

Please note that there are now, from the Feb 2015 Raspbian releases, 3 volume controls for the Pi-DAC+ / Pi-DigiAMP+. This can be confusing but for simplicity just ensure that the Analogue and Analogue Playback Boost volume controls are set to Maximum (100)

- “Digital” is the master volume control 0..100%
- “Analogue” sets the maximum output to be 1vrms (0% = +0db) OR 2vrms (100% = +6db gain)
- “Analogue Playback Boost” gives an additional gain of 0.8db and should similarly be set to 100%

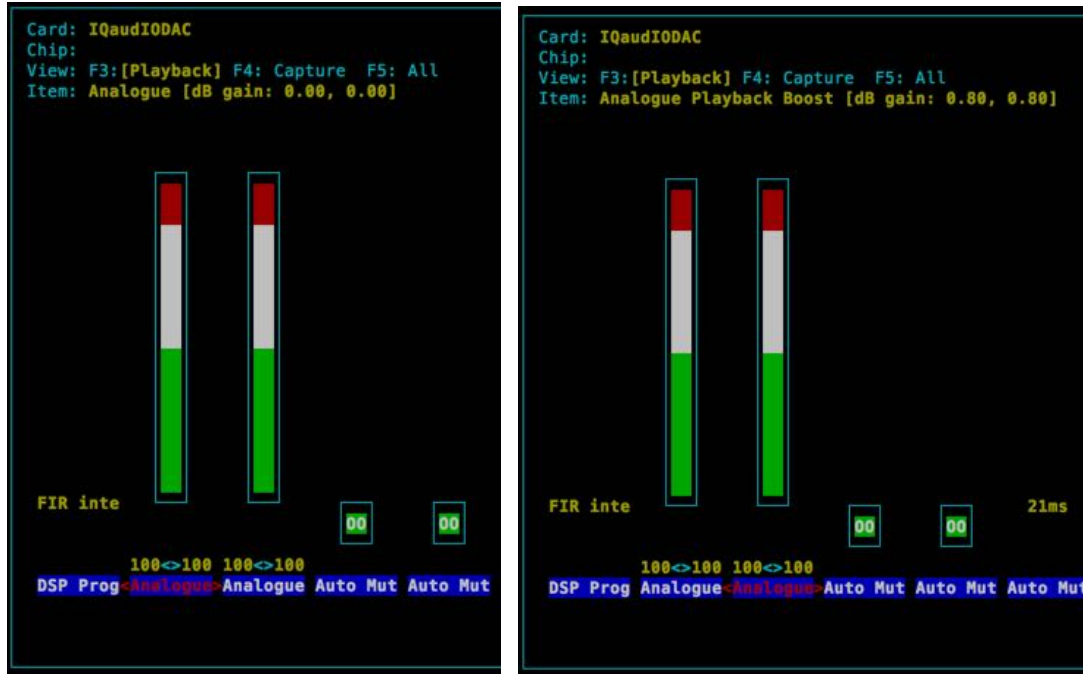

Test that audio can be heard through the Pi-DAC+. Notice the `hw` parameter which points to `device 0, subdevice 0` in the example below. Change these values depending on the specific output of the `aplay -l` utility above.

```
pi@raspberrypi ~ $ mplayer -nolirc -ao alsa:device=hw=0,0 -playlist http://network.absoluteradio.co.uk/core/audio/mp3/live.pls?service=vrhq
```

If you don't have mplayer already installed then this can be done using:

```
pi@raspberrypi ~ $ sudo apt-get update
pi@raspberrypi ~ $ sudo apt-get install mplayer
```

## 14) Advanced troubleshooting

If you are unable to detect the IQaudio sound card (using `aplay -l`) or `alsamixer` doesn't show any IQaudio card then please re-check the section above and ensure that the configuration is correct. If you are still having problems then check that the IQaudio sound card modules are loaded etc.

```
pi@iqaudio ~ $ lsmod
Module                Size  Used by
i2c_dev                6047  0
snd_bcm2835           19769  0
snd_soc_pcm512x_i2c    2129  1
snd_soc_pcm512x       15547  1 snd_soc_pcm512x_i2c
regmap_i2c             2714  1 snd_soc_pcm512x_i2c
snd_soc_bcm2708_i2s    6701  2
snd_soc_iqaudio_dac    2548  0
regmap_mmio           2969  1 snd_soc_bcm2708_i2s
snd_soc_core          132622 3 snd_soc_pcm512x,snd_soc_iqaudio_dac,snd_soc_bcm2708_i2s
snd_compress          7736  1 snd_soc_core
snd_pcm_dmaengine      3287  1 snd_soc_core
snd_pcm               74825 6 snd_bcm2835,snd_soc_pcm512x,snd_soc_core,snd_soc_iqaudio_dac,snd_pcm_dmaengine
snd_seq               53561  0
snd_seq_device         3650  1 snd_seq
snd_timer             18157  2 snd_pcm,snd_seq
i2c_bcm2708           5014  0
snd                   52116 10 snd_bcm2835,snd_soc_core,snd_timer,snd_pcm,snd_seq,snd_seq_device,snd_compress
uio_pdrv_genirq       2966  0
uio                   8235  1 uio_pdrv_genirq
```

dmesg output should also show similar to the the following:

```
[pi@iqaudio ~ $ dmesg
[  3.359858] snd-rpi-iqaudio-dac sound: pcm512x-hifi <-> 3f203000.i2s mapping ok
[ 16.070879] pcm512x 1-004c: No SCLK, using BCLK: -2
```

Note: The following output from `dmesg` is normal:

```
[  4.210755] systemd[1]: Starting Journal Service...
[  4.220932] systemd[1]: Started Journal Service.
[  4.355655] systemd-udevd[109]: starting version 215
[  4.796432] gpiomem-bcm2835 3f200000.gpiomem: Initialised: Registers at 0x3f200000
[  4.800981] bcm2708_i2c 3f804000.i2c: BSC1 Controller at 0x3f804000 (irq 79) (baudrate 100000)
[  4.890738] snd-rpi-iqaudio-dac sound: ASoC: CPU DAI (null) not registered
[  4.890781] snd-rpi-iqaudio-dac sound: snd_soc_register_card() failed: -517
[  4.901458] snd-rpi-iqaudio-dac sound: ASoC: CODEC DAI pcm512x-hifi not registered
[  4.901496] snd-rpi-iqaudio-dac sound: snd_soc_register_card() failed: -517
[  5.044964] EXT4-fs (mmcblk0p2): re-mounted. Opts: (null)
[  5.217873] snd-rpi-iqaudio-dac sound: pcm512x-hifi <-> 3f203000.i2s mapping ok
```

You may notice the above failure messages, this is normal operation as the `pcm5122` device driver is looking for audio boards in two locations, where one will always fail.

## 15) Controlling the Pi-AMP+ / Pi-DigiAMP+'s Mute / Un-mute

MUTE state is toggled by GPIO22 on the Raspberry Pi. The latest IQaudio device tree supports the unmute of the AMP through additional parameters (from Raspbian 4.4.14+ onwards) ...

```
dtoverlay=iqaudio-dacplus,unmute_amp  
"one-shot" unmute when kernel module loads.
```

```
dtoverlay=iqaudio-dacplus,auto_mute_amp  
Unmute amp when ALSA device opened by a client. Mute, with 5 second delay  
when ALSA device closed. (Re-opening the device within the 5 second close  
window, will cancel mute.)
```

If you do not want to control Mute state through device tree then you can also script your own solution. The information below may be useful.

```
# The amp will startup MUTED  
# to unmute the amp.  
pi@raspberrypi ~ $ sudo sh -c "echo 22 > /sys/class/gpio/export"  
pi@raspberrypi ~ $ sudo sh -c "echo out >/sys/class/gpio/gpio22/direction"  
pi@raspberrypi ~ $ sudo sh -c "echo 1 >/sys/class/gpio/gpio22/value"  
  
# to mute the amp once more...  
pi@raspberrypi ~ $ sudo sh -c "echo 0 >/sys/class/gpio/gpio22/value"
```

If you already use WiringPi:

```
# If using WiringPi - to unmute the amp  
gpio mode 3 out  
gpio write 3 1  
  
# to mute once more  
gpio write 3 0
```

For the Pi-AMP+ MUTE may also be disabled at startup by using a jumper across the P9 pins. You may experience a loud crack / pop through attached speakers on power up if this is done. No such jumper pin is available on the Pi-DigiAMP+

For automatic unmute on boot, add the following lines to /etc/rc.local (before the exit(0))

```
#Unmute the Pi-AMP+  
echo "22" > /sys/class/gpio/export  
echo "out" >/sys/class/gpio/gpio22/direction  
echo "1" >/sys/class/gpio/gpio22/value
```

## 16) Raspberry Pi Audio applications

We continue to work with the premier Raspberry Pi audio/media developers (both commercial and open source). Some such applications are downloadable and configurable direct from the software vendors themselves (Max2Play / MoOdeAudio / Volumio, etc) others (RoonLabs / Shairport-sync / etc.) are available pre-configured for download to sd card from our download page [www.iqaudio.com/downloads](http://www.iqaudio.com/downloads)

If you would like to see additional software made available then please email [info@iqaudio.com](mailto:info@iqaudio.com) with the specific details.

### a. RoonLabs

Roon Ready Certified IQaudIO release (for DAC/DigiAMP/DAC P) is available as pre-configured SD card images. The Digi+ image is still in Beta. Both are available here [www.iqaudio.com/downloads](http://www.iqaudio.com/downloads)

### b. Max2Play IQaudIO Special Edition

IQaudIO Special Edition - (<https://www.max2play.com/en/max2play-image/>) support is built in - you can install all IQaudIO cards with just one click.

#### IQaudIO Max2Play Image First Steps

After connecting the Raspberry Pi to the power supply, you can choose to connect to Max2Play in three different ways:

1. Connect an ethernet cable to the Raspberry Pi.
2. Use the WPS feature of your router. [More information](#)
3. Use the Access Point Autostart Mode. [More Information](#)

After connecting in one of these three ways, you are greeted by the Max2Play Start Page. You can now select IQaudIO as the sound card you are using.

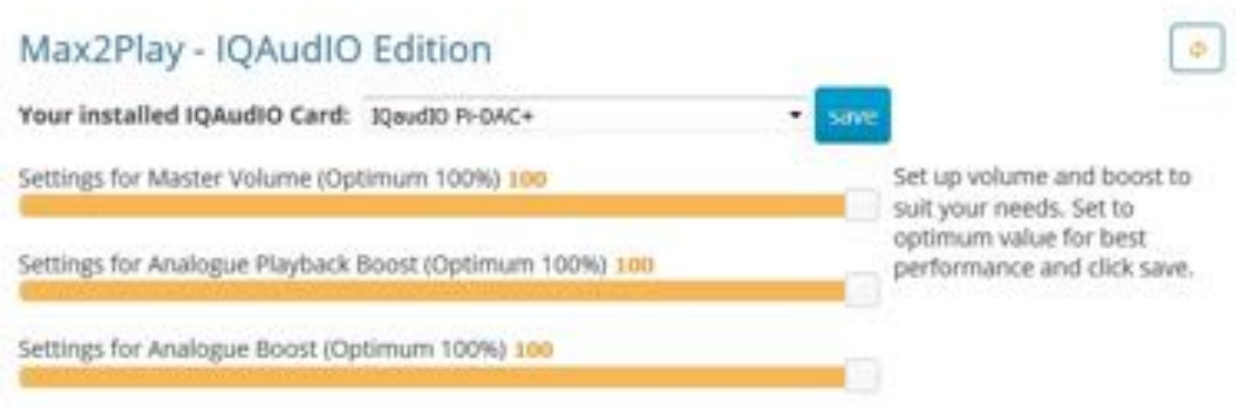

After selecting your sound card from the dropdown menu and rebooting the system, all settings are already made for you and you can choose the audio player you would like to use.

## Additional Settings for IQAudio-Cards

**Rotary Encoder**   IR-Control

Use the rotary encoder as a hardware volume control for your IQAudio Card. The installer sets up everything and adds software to Autostart on Boot.

When using the rotary encoder with Squeezelite, make sure to use hardware volume control and additionally set the Alsa-Sync option in command line options of Squeezelite:

```
-o hw:CARD=IQaudI00AC -V Digital -Q
```

Install Rotary Encoder Software

Autostart Rotary Encoder Software:  save

If you have a Rotary Encoder, you can also directly install it with one click in the same menu and just add the hardware volume control line to the Advanced Options' command lines of the audio player you would like to use.

For more guidance and to follow along the settings, you can also check out [the YouTube video](#) on the IQaudIO Plugin by Max2Play.

### c. Volumio (<https://volumio.org/get-started/>)

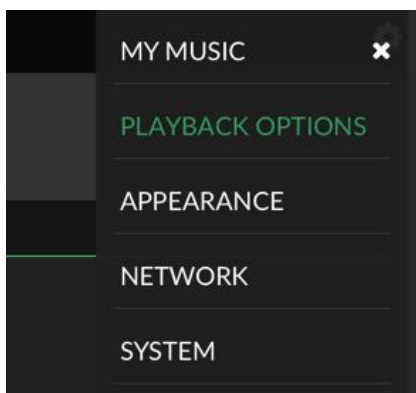

From a fresh distribution of Volumio you will find that IQaudIO support is built in.

Write SD card image and boot Pi.  
connect from web browser to volumio.local

Select the top right hand side (burger) menu and select PLAYBACK OPTIONS.

Here change the audio interface to I2S, and select IQaudIO Pi-DigiAMP+ for "DAC Model".

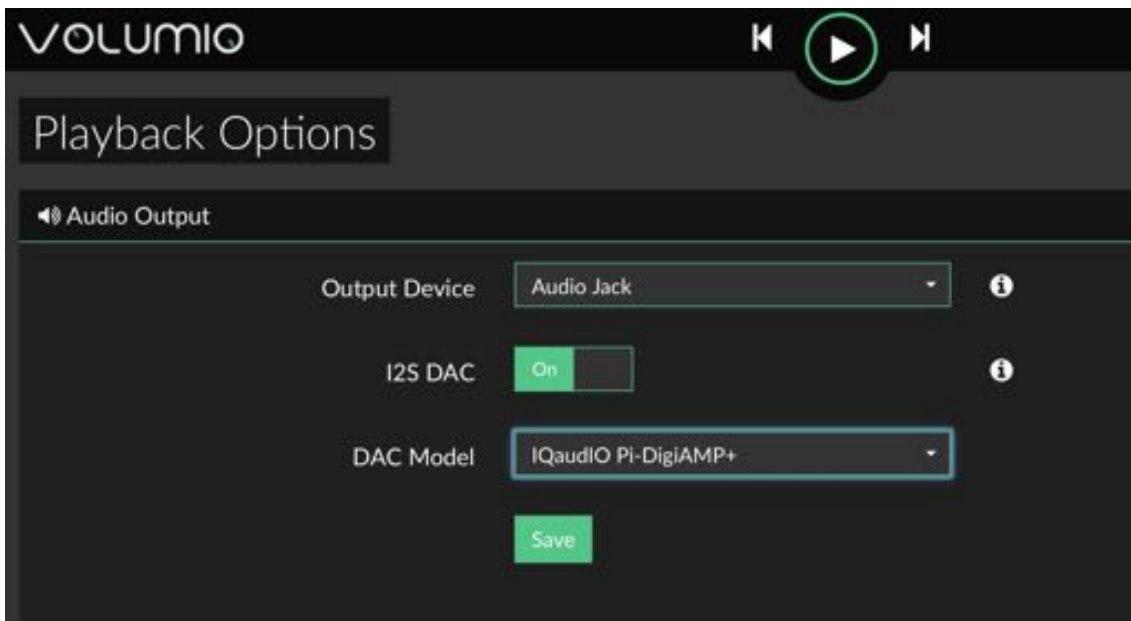

This will work with AMP/DAC/DAC PRO/DigiAMP.

Press Save, and you will be prompted to reboot.

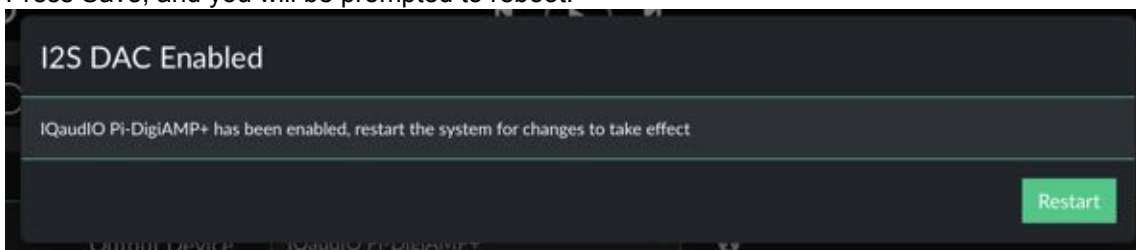

Restart Volumio for this change to persist.

Once Volumio has restarted, once again select Menu/Playback options.

Ensure that the Volume Options have the Mixer type as Hardware, and that the Mixer Control Name is set to "Digital".

Press SAVE.

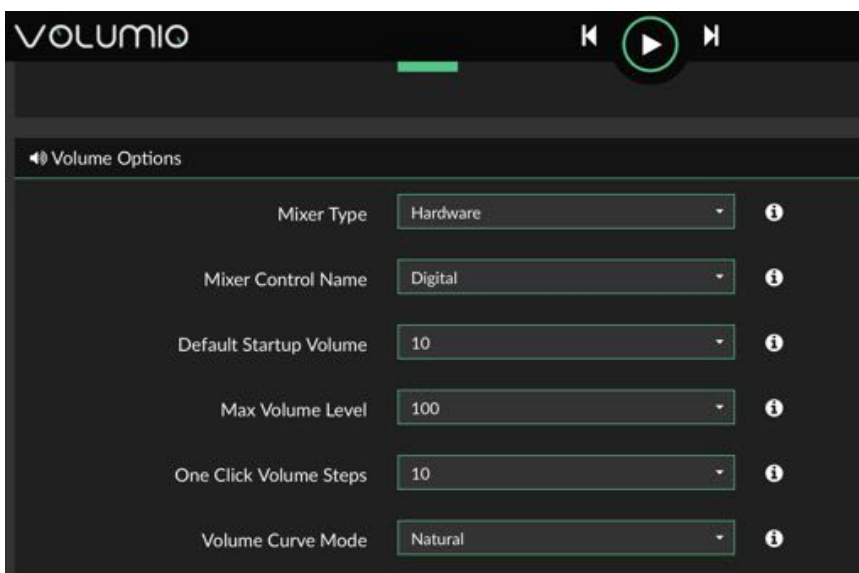

Pre-configured SD card images are available at [www.iqaudio.com/downloads](http://www.iqaudio.com/downloads)

#### **d. MoodeAudio (<http://www.moodeaudio.org>)**

From a fresh distribution you will find that IQaudIO support is built in.

connect from web browser to moode.local

select configure from the pull down menu, then system.

Within the Audio section select the IQaudio device you have (such as Pi-DAC+) and press SET

Within the same selection make sure you set the volume to around 20% (not 100%) and press SET

Select reboot

Once reconnected....

Select configure from the pull down menu and then MPD

Within Setting, select volume control - hardware and then APPLY

Select reboot

#### **e. RuneAudio (<http://www.runeaudio.com>)**

From a fresh distribution you will find that QaudIO Pi-DAC+ support is built in.

Write SD card image, boot Pi.

ssh into the Pi as root (password rune) and edit /boot/config.txt to select the IQaudio Pi-DAC+ devicetree overlay. Save and reboot

connect from web browser to runeaudio.local

select the pull down settings menu and select MPD, here change audio interface to IQaudIO DAC, beneath this select Volume control: enabled-hardware

Press SAVE AND APPLY

#### **f. Bob Rathbone's Internet Radio ([http://www.bobrathbone.com/raspberrypi/pi\\_internet\\_radio.html](http://www.bobrathbone.com/raspberrypi/pi_internet_radio.html))**

Bob's website has a huge amount of documentation to support the construction of purposeful internet radio's around the Raspberry Pi. He includes many details on IQaudIO board support and also includes support for the IQaudIO CosmicController buttons, volume control and mini-OLED display.

#### **g. PiCorePlayer (<https://sites.google.com/site/picoreplayer/home>)**

IQaudIO support is built in.

#### **h. PiMusicBox (<http://www.pimusicbox.com>)**

IQaudIO Pi-DAC+ support is built in.

#### **i. Raspbian (<https://www.raspberrypi.org/downloads/>)**

IQaudIO support is easily enabled as documented in this user guide

#### **j. OpenElec (<http://openelec.tv/get-openelec>)**

IQaudIO Pi-DAC+ support is configurable.

- Download Stable Openelec 6.0.3 image from <http://releases.openelec.tv/OpenELEC-RPi2.arm-6.0.3.img.gz>
- write image to SD card
- Boot Openelec



- SSH into the Raspberry PI and edit config.txt to include the IQaudio device tree
  - mount -o remount,rw /flash
  - nano /flash/config.txt
    - # audio interfaces
    - dtoverlay=iqaudio-dacplus
    - # optional hardware interfaces
    - dtparam=i2s=on
  - Once above changes have been made, then ctrl+x to save.
  - mount -o remount,ro /flash
  - reboot

### **k. OSMC (<https://osmc.tv>)**

IQaudio Pi-DAC+ support is configurable.

Pre configured versions are available at [www.iqaudio.com/downloads](http://www.iqaudio.com/downloads)

### **l. Others**

If you know of others please let us know by emailing us at [info@iqaudio.com](mailto:info@iqaudio.com)

## 17) Advanced hardware details

The following section is for more advanced users.

Software:

- Depending on the Linux kernel version, the audio mixer / volumes will report the Hardware volume mixer as either “PCM”, “Playback Digital” or more recently just “Digital”. Please see alsamixer for the name used in your particular kernel version.
- Not all features of the PCM512x device driver have been fully tested. Changing settings other than the standard Mixer may NOT provide the expected result.
- We expect the following Raspberry Pi GPIO to be used by IQaudIO products
  - GPIO22 (AMP+ & DigiAMP+ mute / unmute support)
  - GPIO23/24 for our Rotary Encoder (volume control) software
  - GPIO25 for the IR Sensor software.

Hardware I/O information (**Pi-DAC+**, **PiDAC PRO**, **Pi-Digi+**and **Pi-DigiAMP+**):

Pi-DAC+/Pi-DigiAMP+ SIGNALS USED					
Pin#	NAME		NAME	Pin#	
	1	3.3v (DC)	(DC Power) 5v	2	
Used by Pi-DAC+ (I2C) ----->	3	GPIO2 (I2C)	(DC Power) 5v	4	
Used by Pi-DAC+ (I2C) ----->	5	GPIO3 (I2C)	(GROUND) 0v	6	
(Pi-DAC uses I2C address	7	GPIO4 (GCLK)	(TXD0)	8	
	9	0v (GROUND)	(RXD0)	10	
	11	GPIO17 (GEN0)	(I2S CLK)	12	<----- Used by Pi-DAC+ (I2S)
	13	GPIO27 (GEN2)	(GROUND) 0v	14	
Pi-DigiAMP+/ Pi-AMP+ ----->	15	GPIO22 (GEN3)	(GEN4)	16	<----- Used by Rotary
	17	3.3v (DC)	(GEN5)	18	<----- Used by Rotary
	19	GPIO10	(GROUND) 0v	20	
	21	GPIO9	(GEN6)	22	<----- Used by IR Receiver
	23	GPIO11	(SPI CE0)	24	
	25	0v (GROUND)	(SPI CE1)	26	
Used by Pi-DAC+ EEPROM ----->	27	ID_SD (HAT)	(HAT	28	<----- Used by Pi-DAC+
	29	GPIO5	(GROUND) 0v	30	
	31	GPIO6	GPIO12	32	
	33	GPIO13	(GROUND) 0v	34	
Used by Pi-DAC+ (I2S) ----->	35	GPIO19 (I2S)	GPIO16	36	
	37	GPIO26	(I2S DIN)	38	<----- Used by Pi-DAC+ (I2S)
	39	0v (GROUND)	(I2S DOUT)	40	<----- Used by Pi-DAC+ (I2S)

The New Pi-DAC+ / Pi-DigiAMP+ / Pi-DAC PRO re-exposes the Raspberry Pi signals including UART / SPI CS:

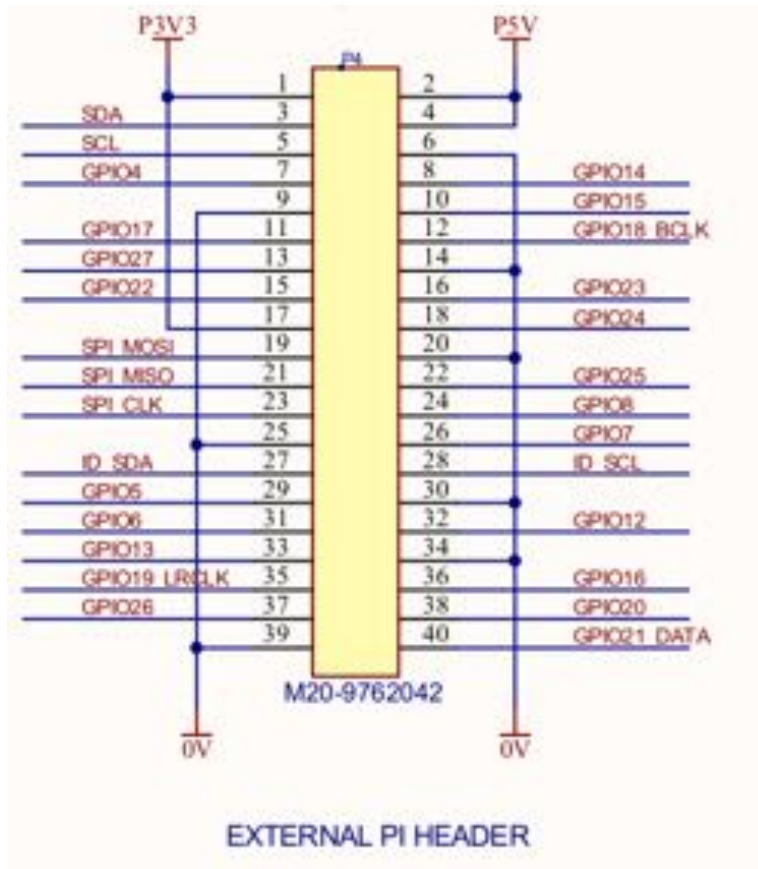

## Pi-DACZero

The Pi-DACZero exposes a 2x4 pin header user to connect the DACZero Headphone daughter card. The details of this pin header are:

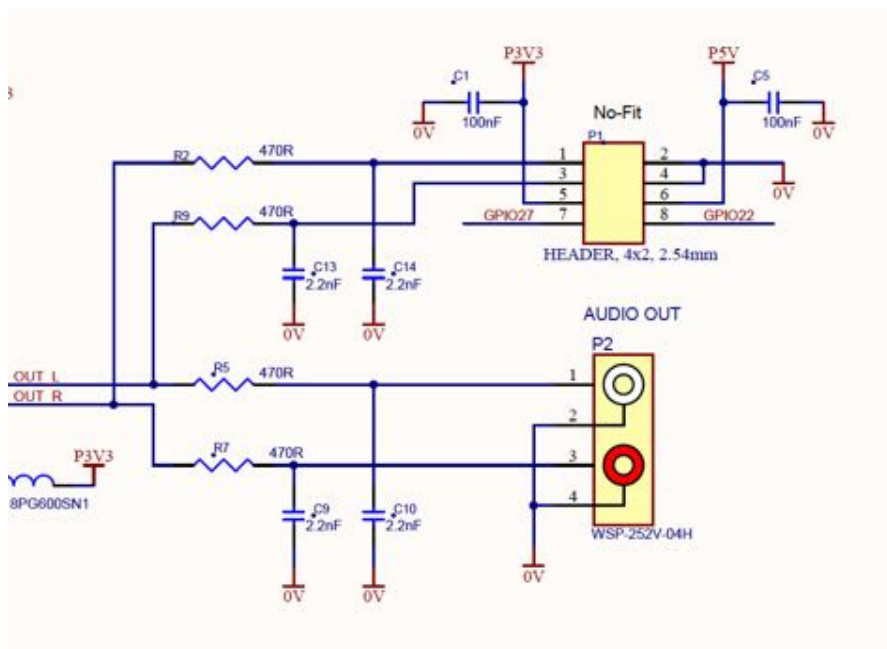

Signals passed through by Pi-DACZero (P2)				
Pin#	NAME		NAME	Pin#
1	RIGHT OUT	□	(GROUND) 0v	2
3	LEFT OUT	□	(GROUND) 0v	4
5	3v3 (DC Power)	□	(DC Power) 5v	6
7	GPIO27	□	GPIO22	8

## Pi-DAC PRO

The Pi-DAC PRO exposes two 3 pin headers (P7/P9) for Differential / Balanced output. These pins can be wired to XLS sockets if needed. Pin 1 is square.

Differential / Balanced output pins		
Pin	NAME	
1	GROUND	□
2	+ve	□
3	-ve	□

## 18) Adding a Rotary Encoder

The following section shows the recommended pins / GPIO to use when adding a Rotary Encoder (physical volume control) and using the IQ\_rot utility (from our github site: [www.github.com/iqaudio/tools](http://www.github.com/iqaudio/tools)) or similar to control the ALSA audio volume level.

IQ\_rot utility assumes that a 3 pin rotary encoder is connected to the Raspberry Pi as follows.

With the rotary encoder shaft facing you and pins facing downwards:

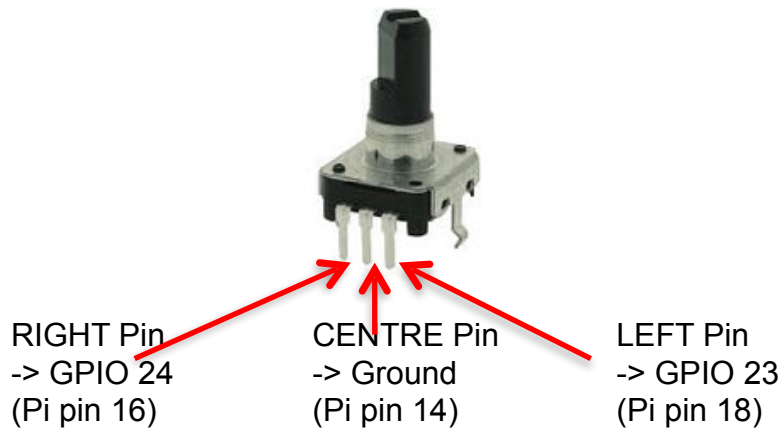

IQ\_rot needs to be run with root privileges (`sudo IQ_rot`) and needs the WiringPi library to be pre-installed. If being run at startup (in `/etc/rc.local`) make sure that the call is done as a separate process (for example as: `/usr/pi/iqaudio/tools/IQ_rot&`)

By default IQ\_rot uses the mixer name Digital – if the driver's volume control mixer is not "Digital" then the IQ\_rot source code will need to be modified to access the correct mixer.

## 19) Sonic\_Pi and IQaudIO

It is now possible to use Sonic\_Pi with the IQaudIO devices. Simply add the following device tree overlay to your /boot/config.txt and reboot. The latest Raspbian releases include i2s-mmap enabled by default.

```
dtoverlay=i2s-mmap
```

## 20) Saving alsamixer settings

Storing the alsamixer setting can be achieved by performing the following at the command line:

```
sudo alsactl store
```

## 21) Using external USB devices

Note that if you want to enable 1.2AMP USB support (to allow USB hard disks to power up when the Pi-DAC+ / AMP+ is in use) then you may also want to add the following line to your /boot/config.txt file:

```
max_usb_current=1
```

Please ensure your Pi power supply is able to deliver ~2amp if you are powering via mini USB and enable max\_usb\_current

## 22) MPD based audio with volume control

To allow clients to control volume, /etc/mpd.conf needs the volume control adding to the audio\_output section. Without this you can control volume other ways, but mpd clients can't do it directly.

This can be achieved by ensuring the 'Audio Output' section of /etc/mpd.conf has the 'mixer\_control' line below.

```
audio_output {
    type      "alsa"
    name      "ALSA Device"
    mixer_control "Digital"
}
```

### 23) Useful data (screw sizes / part numbers / wire gauge size etc.)

The full range of IQaudio sound cards and accessories are available directly from IQaudio Limited ([www.iqaudio.com](http://www.iqaudio.com)) or through various Worldwide distribution channels. Please note that although most distributors of our products supply the same optional extras such as PCB standoffs / optional pin headers etc., not all of those selling our products do. If your distributor doesn't include these items then you can either source them yourself or purchase them from us directly for a small charge.

#### Useful Data:

- Screws etc. are all m2.5
- PCB standoffs (for Pi-CASE) are 5mm male / female
- PCB standoffs (for Pi to IQaudio products) are 9mm female / female
- PCB standoffs (for Pi to IQaudio LEGACY products) are 11mm female / female
- PCB standoffs (for Pi-AMP to Pi-DAC) are 11mm female / male
- PCB standoffs (for the official Raspberry Pi 7" display) are 5mm male / female\*
  
- The rotary encoders we have used and tested are the ALPHA 3 pin Rotary Encoder RE160F-40E3-20A-24P, the ALPS EC12E2430804 (RS: 729-5848), the Bourns ECW0J-B24-AC0006L (RS: 263-2839)
  
- The Power Barrel for Pi-AMP+ & Pi-DigiAMP+ is 2.5mmID, 5.5mmOD, 11mm
- New Pi-DigiAMP+ is designed to operate with a 12v 3amp to 24v supply such as the XPPower VEC65US19 or similar
- Legacy Pi-AMP+ is designed to operate with a 12v 3amp to 19v supply such as the XPPower VEC65US19 or similar
- The New Pi-DigiAMP+ uses CamdenBoss two part connectors. Those fitted to the PCB are: [CTBP9350/2AO](#)
  
- The JST connector used on the Pi-AMP+ and Legacy Pi-DigiAMP+ is JST, EH series, 2-pin, 2.5mm pitch, 3A
- The speaker Terminals used on the Pi-AMP+ & Pi-DigiAMP+ will accept wires of between 14 ~ 26 AWG (wire of max 1.6mm in diameter)